

Mounting Instructions

HÄFELE

Item No.: 237.56.050/055

EFL10 Cabinet Locks

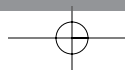
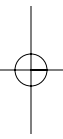
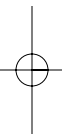
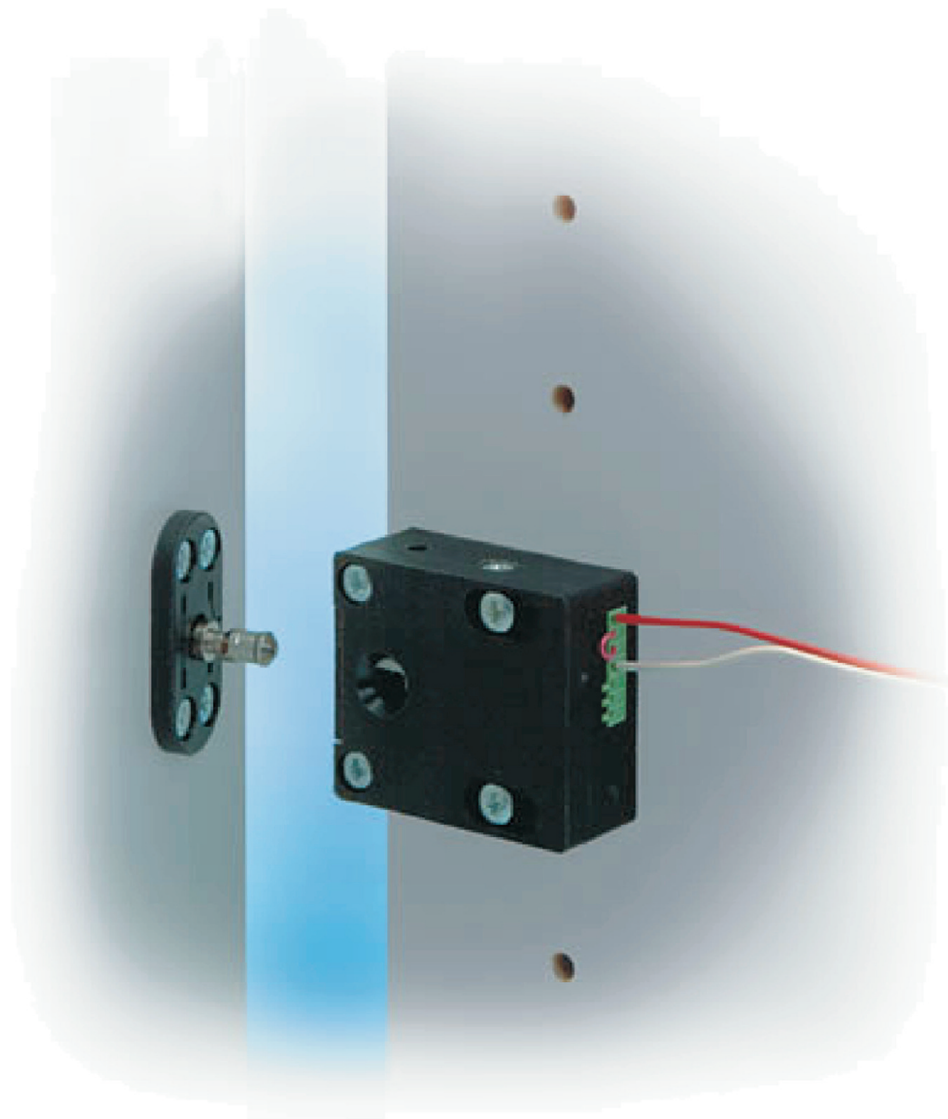

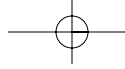

Contents

General Description	11
Functional characteristics	
Fail-unlocked and fail-locked operation	11
Setting of operating mode fail-unlocked or fail-locked	12
Mounting	
Dimensioned drawing	12
Mounting instructions	13
Positioning of compact lock and rosette	13
Mounting examples	14
Drawer	14
Fitted cupboard	14
Electric supply	
Connecting diagram	15
Technical data	15

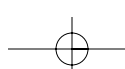
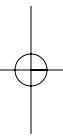
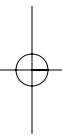

General description

The compact locking units 1049.10 and 1049.10 RR have especially been developed for the locking of furniture. They can be used instead of usual mechanical lockings or additionally as an access control system and prevent unauthorized access to valuables or certain documents.

The compact locking units can be used for locking filing cabinets, drawers, post-office boxes / safe-deposit boxes and glass cabinets.

The most simple way to operate the access control system is by means of a key switch. If it is necessary to electronically control, register and monitor the access control system, the compact locking unit can be combined with a code or card reader system.

The RR version additionally incorporates a change-over contact for monitoring the state of the door (open/closed).

Taking into account the varied possibilities to use the compact locking unit, it can be operated in the fail-unlocked mode as well as in the fail-locked mode.

The field reversibility is easily executed in no time during the installation of the unit by positioning the rosette accordingly.

Due to the integrated mechanism that keeps the door closed, the door of a filing cabinet, for example, is kept closed even if it is unlocked. Consequently, additional mechanisms for keeping the door closed (e.g. magnetic snaps) are not required.

Fail-unlocked and fail-locked operation:

The difference between the fail-unlocked and the fail-locked operating mode is the following: the fail-unlocked version must be energized in order to be locked whereas the fail-locked version must be energized in order to be unlocked.

Note

Fail-locked operation means that in the event of power failure unlocking is impossible and consequently the door cannot be opened.

Functional characteristics:

The compact locking unit 1049.10/1049.10 RR consists of two parts. Part 1 is the locking element which is mounted laterally to a safe-deposit box. Part 2 is the rosette which is installed at the door.

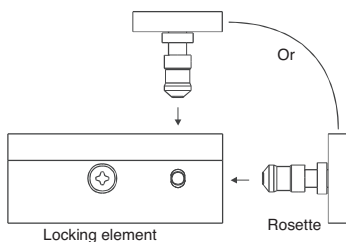

Illustration 1: Locking principle

When the door is closed, the locking bolt of the rosette engages the locking element and the safe-deposit box is locked. If the safe-deposit box must be opened, the compact locking element must be unlocked electrically first.

According to the requirements, the compact locking unit can be installed for front or top engagement of the rosette (see illustration 1).

Setting of fail-unlocked or fail-locked operating mode

Two pictograms are printed on the rosette, one for fail-unlocked and one for fail-locked mode (see illustration 2). For operation in the fail-unlocked mode, the mark on the locking element must point to the fail-unlocked pictogram of the rosette. For operation in the fail-locked mode, the mark must point to the fail-locked pictogram.

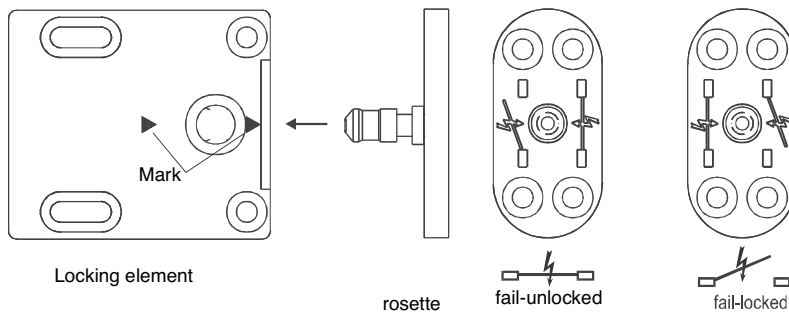

Illustration 2: Alignment of the rosette

Mounting

Mounting and adjustment only when the rosette is in the fail-unlocked position in case the compact locking unit cannot yet be unlocked electrically. Otherwise, it would not be possible to open the door or the drawer any more.

Four cylindrical countersunk mounting holes each are provided for mounting the locking element as well as the rosette. For position of mounting holes see drawing. Reducing bushes, screws and washers are included in the mounting material supplied.

Before fastening the two special steel washers with screws, they must be placed into the elongated holes of the locking element.

Dimensioned drawing:

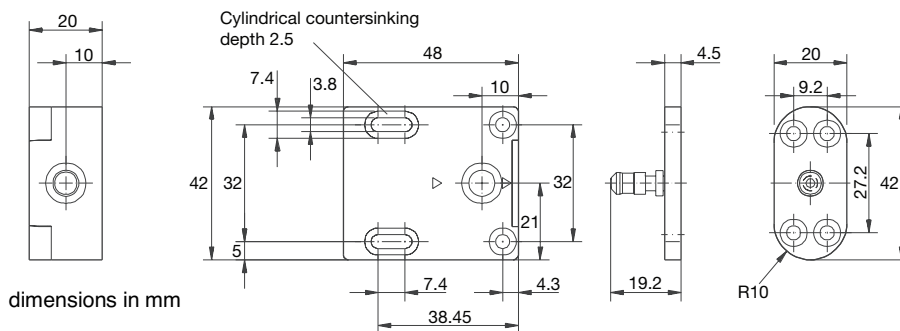

dimensions in mm

Illustration 3: Dimensioned drawing

Mounting instructions:

Locking element and rosette must be aligned as shown in illustration 4 (flush). When closing the door or drawer, the locking bolt of the rosette must be able to engage the locking element completely. Furthermore, no tensile force caused by the door respective to the drawer must act on the locking element. The rosette can be mounted by screws and is also suitable for flush mounting. The adjustment of locking element and rosette must be achieved by means of the elongated holes in the locking element. An adhesive film (adhesive on both sides) is supplied which can be applied to the back of the rosette. This will help you to find the correct position of the rosette.

After applying the adhesive film, the rosette must be put into the mounted locking element with fail-unlocked setting and the door must be closed. When the door is opened, the rosette is in the correct position. After marking the drilling points, the rosette must be turned through 180°.

Under no circumstances must the rosette be mounted as shown in illustration 5 – turned through 90°. If the locking bolt of the rosette engaged the locking element, it would not be possible to open the door or drawer.

Correct positioning: The locking bolt of the rosette engages the locking element completely.

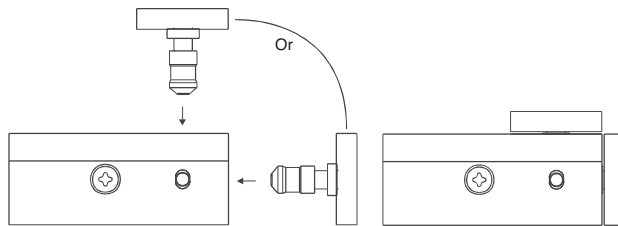

Illustration 4: Mounting instruction

Wrong positioning: The rosette turned - through 90°.

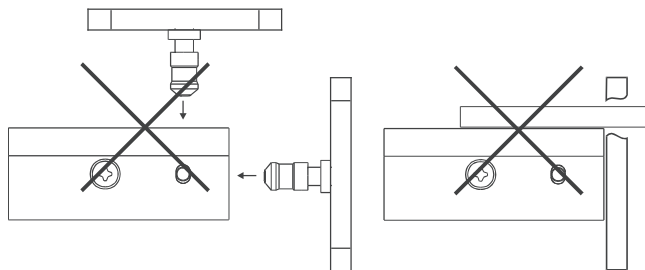

Illustration 5: Mounting instruction

Mounting examples:

Illustrations 6 and 7 show options for mounting the compact locking unit to a desk with drawers or to a fitted cabinet.

Accessories are supplied with the compact locking unit. They consist of fixing screws and washers for the locking element and the rosette as well as reducing bushes for the installation in existing bore holes.

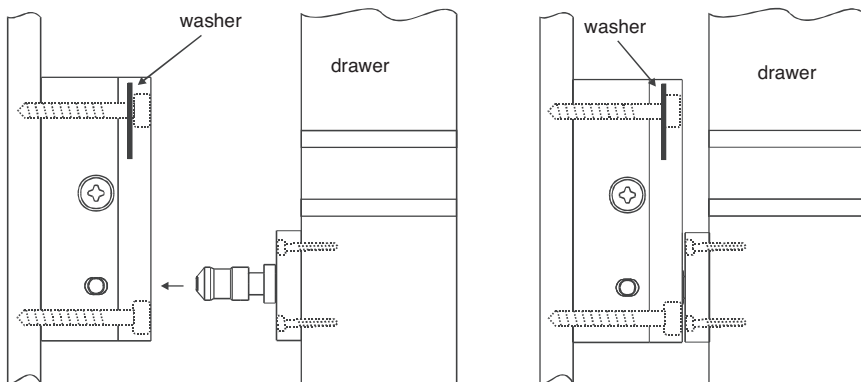

Illustration 6: Mounting to a drawer

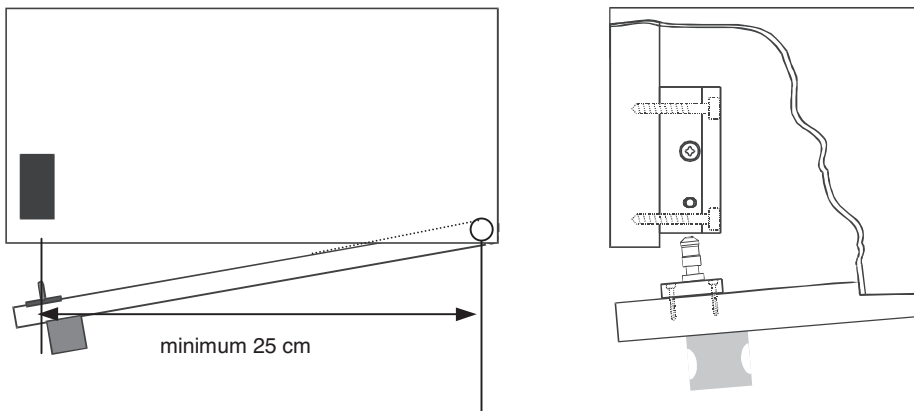

Illustration 7: Mounting to a cabinet

Electric Supply

With regard to continuous duty operation, the compact locking units 1049.10 and 1049.10 RR must be operated with stabilized DC, 12 V or 24 V. Unlocking by AC is possible, however, it is not recommended due to the buzzing sound caused. Connections must be achieved according to the connecting diagram (see illustration 8). The necessary jumpers as well as the diodes are included with the accessories.

Model 1049.10 RR additionally incorporates a change-over contact which monitors the state of the door (open/closed).

When determining the wiring please take into consideration that the supply voltage – measured at the terminals – is not lower than the minimum indicated.

Connecting Diagram:

Instructions for connection: loosen the screws of the required terminals by turning them counter-clockwise (3-4 turns). Insert the lead into the terminal. For fastening the terminal retighten the screws by turning them clockwise.

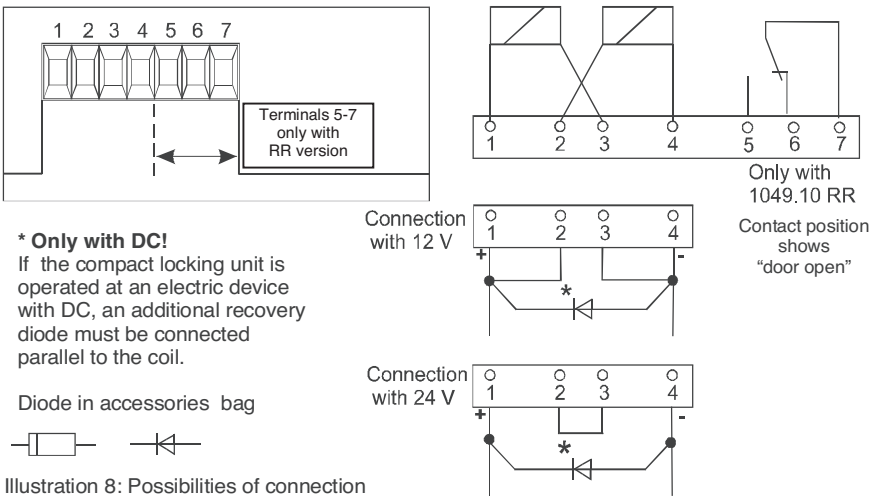

Illustration 8: Possibilities of connection

Technical data:

mode of operation	fail-unlocked or fail-locked operation momentary or continuous unlocking			
	12V DC stab.	12V AC buzzing sound	24V DC stab.	24V AC buzzing sound
operating voltage				
connecting voltage	operating voltage ± 10%			
current consumption typ.	260 mA	140 mA	130 mA	70 mA
max.cap. of the RR contact	25 V/ 1A			
tensible strength	1000 N (≈100 kp)			
type of protection according to DIN 40050	IP 20			
housing temperature	continuous energization: approx. 60°C			
temperature range	+10°C - +40°C			
dimensions in mm (L x W x H) locking element w/o rosette	48 x 42 x 20			

HÄFELE

3901 Cheyenne Drive
 P.O. Box 4000
 Archdale, NC 27263
1-800-423-3531
www.hafele.com