

# Mounting Instructions

HÄFELE

Item No.: 237.56.000, 237.56.002, 237.56.004

## EFL1 Furniture Lock





### Areas of application:

The Dialock furniture locking (EFL1) locks are used for the electro-mechanical locking of cabinets, drawers, doors, etc.

### Supplied with:

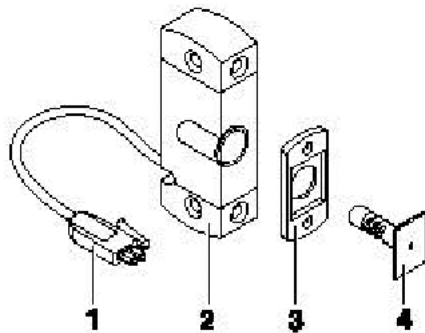

1. AMP connector (supplied, but not connected to the EFL1 lock case)
2. EFL1 lock with power cable
3. Fixing Plate
4. Locking Bolt

### NOTE:

Drill jig, Article No. 237.56.990, must be ordered separately.

### Technical Information:

The EFL1 lock is controlled via a Multi Output Terminal with output extender. Up to 128 EFL1 locks can be controlled by means of one single terminal. Simple applications can also be employed with the wall terminal control.

### Technical Data:

Power Supply	12VDC
Continuous Current Consumption	50mA
Tensile Load	> 200 N, acc to DIN 68 852 or 90 kg force

## Installation:

Tools needed:

- Phillips or #2 screwdriver
- Marker or pencil
- Screws:
  - Wooden cabinet and door: 4 #6 wood screws ( $\varnothing$  3.5mm x Xmm, depending on the thickness of the cabinet)
  - If otherwise: corresponding screws, e.g. self-tapping screws with metal cabinets
- Drill Jig
- Power Supply, Article No. 917.93.004 or .005

Pre-conditions:

- Door width with inset doors: minimum 240 mm
- Door width with overlay doors: minimum 240 mm

Recommendation:

- With cabinet doors: use self-closing hinges
- With drawers: use self-closing drawer slides

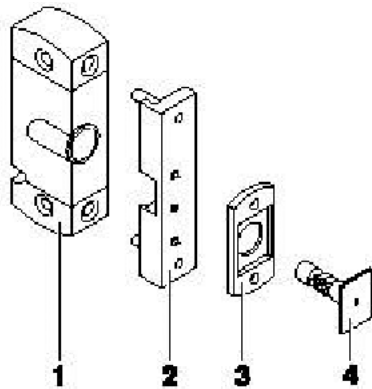

1. EFL1 lock
2. Drilling Jig
3. Fixing Plate
4. Locking Bolt

1. Position drilling jig and EFL1 lock

If the locking bolt is inserted in the EFL1 lock:

- Connect the power supply and remove the locking bolt from the EFL1 lock by pulling it out.

2. Put the drill jig on the EFL1 lock.

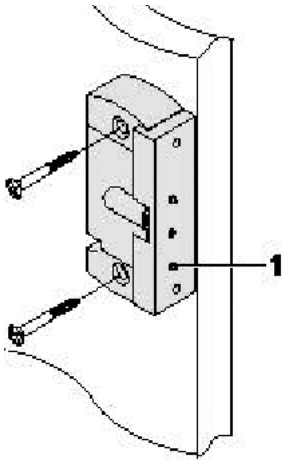

1. Pins of the Drill Jig
2. Place the EFL1 lock at the cabinet inside of the corresponding piece of furniture using the drill jig.
  - With overlay doors: adjust the drill jig so that it is flush with and parallel to the front edge of the cabinet.
  - With inset doors: position the EFL1 lock to the inside by the dimension of the door thickness. Put the drill jig in such a manner that it is positioned parallel to the cabinet edge.
  - Doors with stoppers: in addition position the EFL1 lock to the outside by the thickness dimension of the stoppers.
3. Use the marker or pencil to mark the screw holes.
4. Use 2 #6 wood screws ( $\varnothing$  3.5mm) to secure the EFL1 lock to the furniture cabinet. For adjustment, leave the drill jig in position on the cabinet panel.
5. Push the door against the placed drill jig. The screw holes for the installation of the fixing plate of the locking bolt are marked by the drill jig.

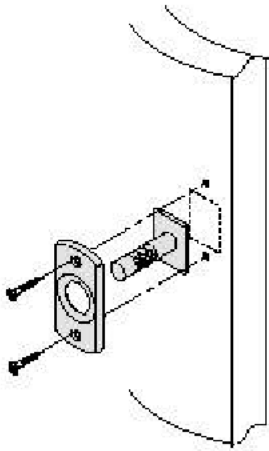

6. Put the locking bolt through the fixing plate and screw it to the door with 2 Hospa screws.
7. Run the power cable on the inside of the furniture.
8. Plug the 2 pins into the AMP plug housing until the pins engage. Now press the 2 outer jacket sleeves of the AMP plug together.
9. Connect the AMP connector of the EFL1 lock to the power supply and check for functioning. Door must open and close without any problems.
10. Plug the AMP plug into the output extender or into the mounting block (shown later).

### CNC dimensions

If the EFL1 lock is pilot-drilled by means of a CNC-machine, observe the following dimensions:

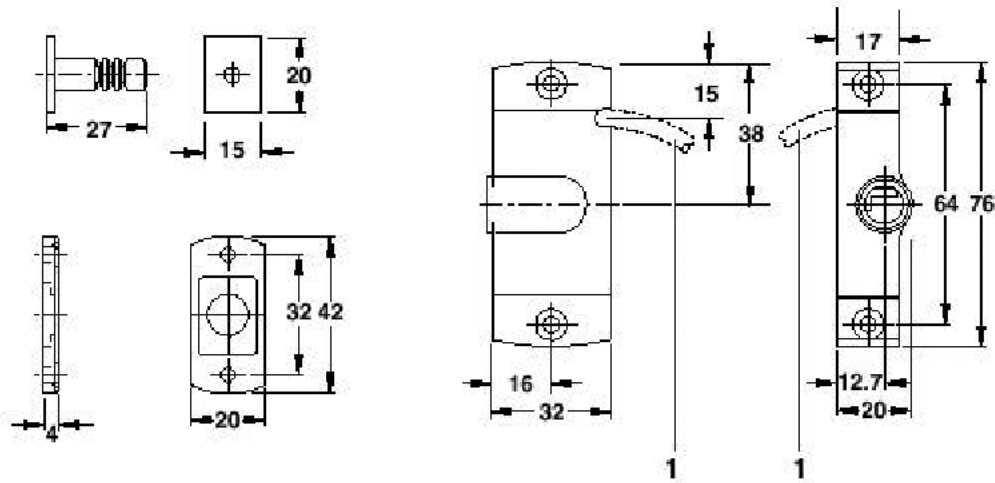

Dimensions of the EFL1 lock (individual components):

1 Cable outlet

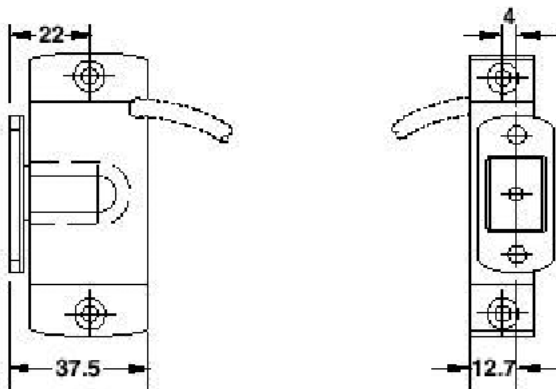

Dimensions of the EFL1 lock (closed condition):

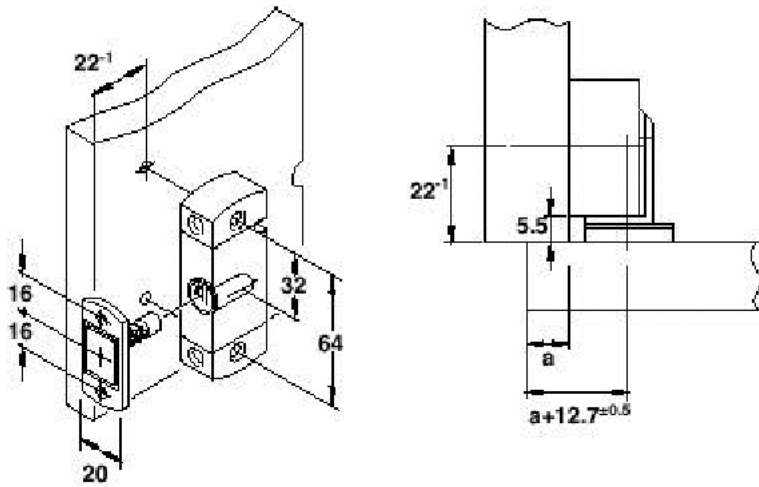

Drilling dimensions for installation on overlay door:

A Overlay of door

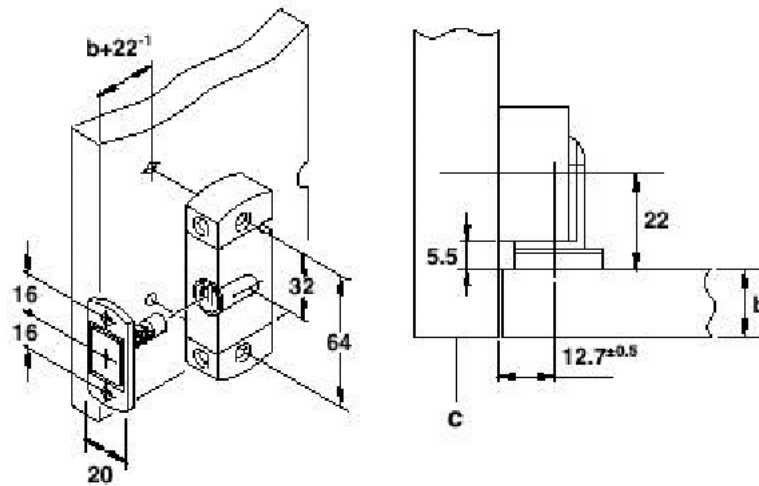

Drilling dimensions for installation on inset door:

- B Thickness of door (if door is flush with cabinet front edge)
- C Cabinet from edge

Drilling dimensions for installation on drawers:

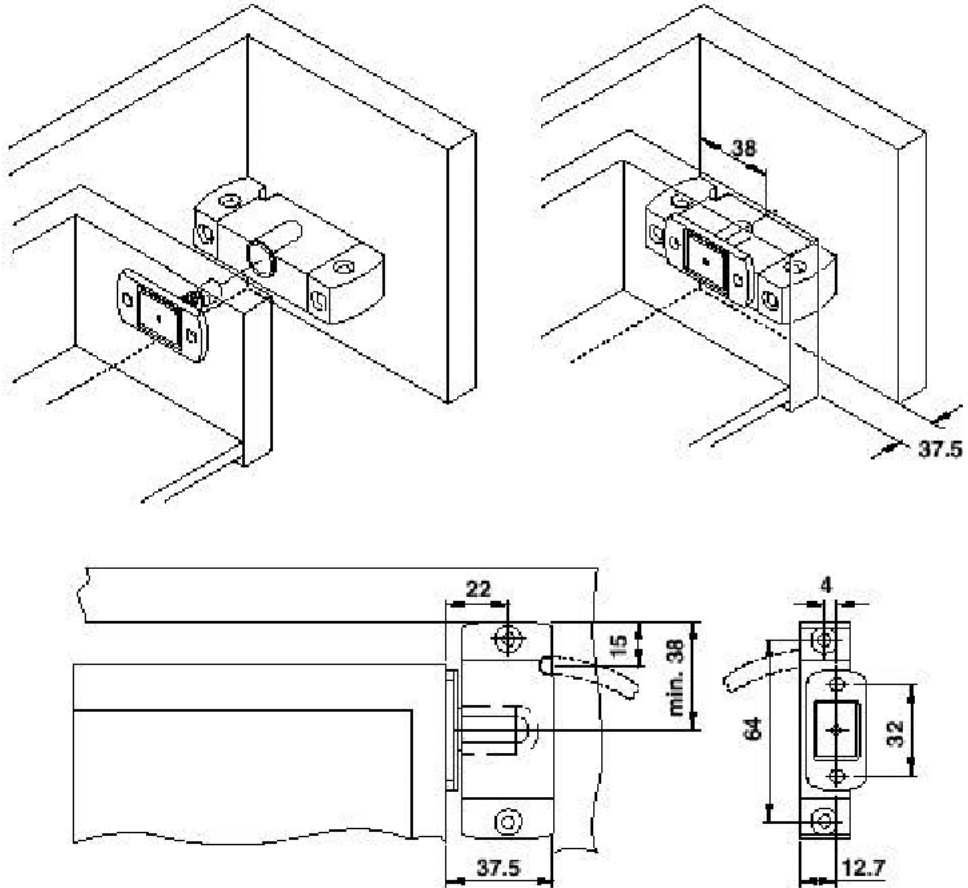

**Connection of up to 15 EFL1 locks to the wall terminal**  
**Damage to the wall terminal relay contacts**

- Always use a recovery diode if the EFL1 lock is controlled by a wall terminal.

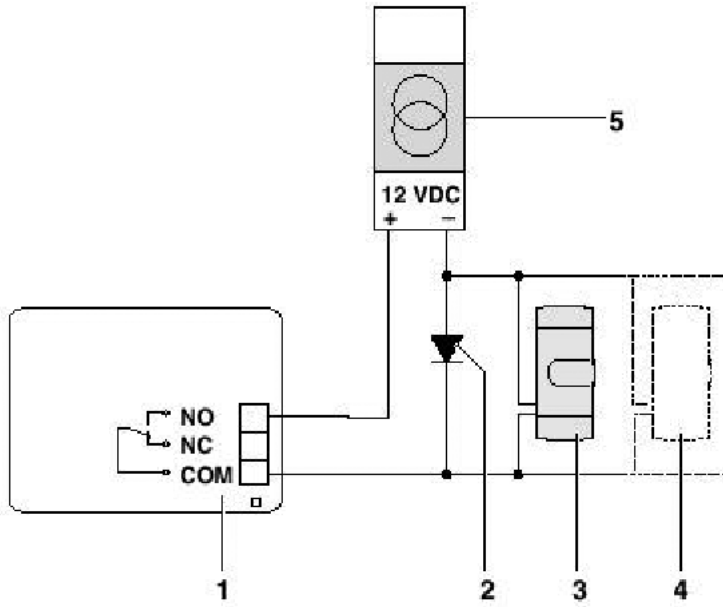

1. Control electronics module of the wall terminal
2. Recovery diode
3. EFL1 lock
4. Additional EFL1 locks
5. Power supply for EFL1 locks

- Insert the recovery diode into the circuit parallel to the EFL1 lock (as shown). Make sure the wiring is performed by a qualified electrician. The casing of the control electronics module is equipped with terminals for connection of the recovery diode.

## Connection of more than 15 EFL1 locks to the wall terminal

A separate power supply for both wall terminal and locks is needed when connecting more than 15 EFL1 locks to the wall terminal. In this case, an external relay must be connected in series.

---

### Damage to the relay contacts

- Always use a recovery diode if the EFL1 locks are controlled via wall terminal.
- 

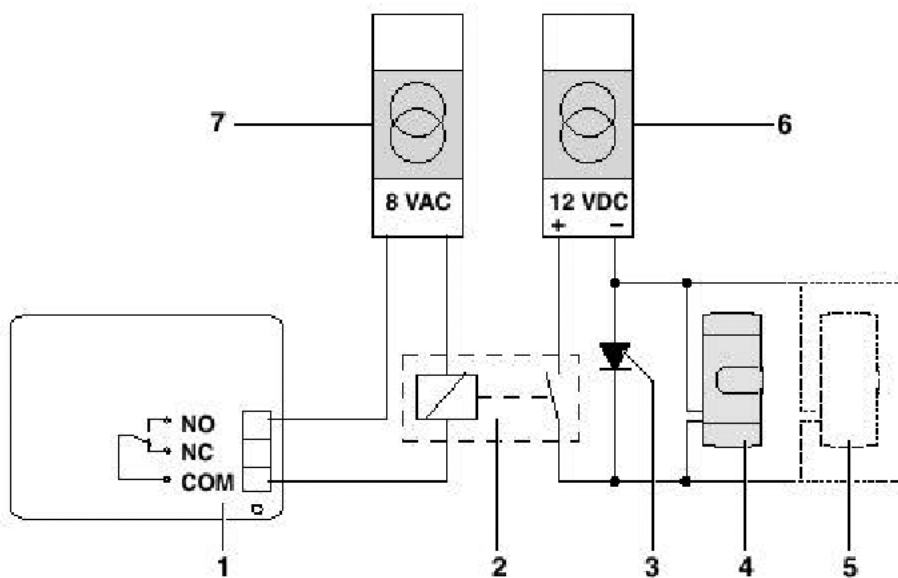

1. Control electronics module of the wall terminal
2. External relay
3. Recovery diode
4. EFL1 locks
5. Additional EFL1 locks
6. Power supply for EFL1 locks
7. Power supply for external relay

- Insert external relay and recovery diode in the circuit (as shown). Make sure the wiring is performed by a qualified electrician.

## Wiring Examples

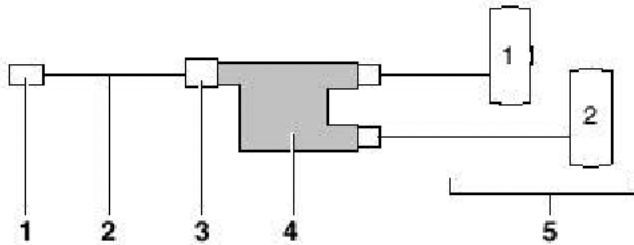

Connection with 1-2 distribution block

1. AMP plug
2. Extension cord
3. AMP cap
4. 1-2 distribution block
5. EFL1 locks

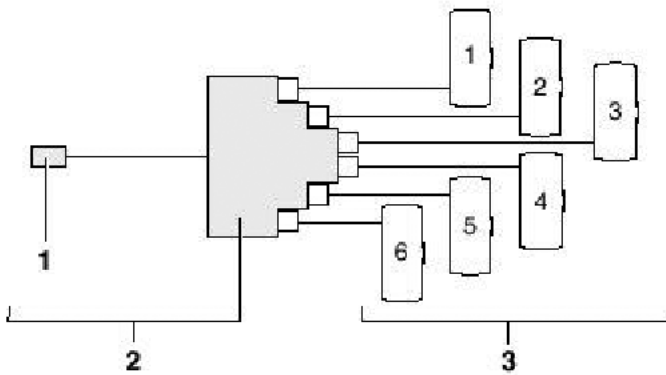

Connection with 1-6 distribution block

1. AMP plug
2. 1-6 distribution block
3. EFL1 locks

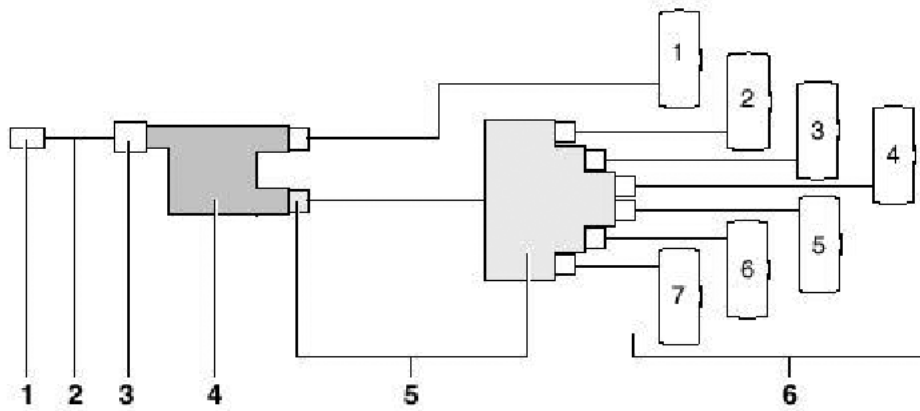

Connection with combined 1-2 way and 1-6 way distribution blocks.

1. AMP plug
2. Extension cord
3. AMP cap
4. 1-2 distribution block
5. 1-6 distribution block
6. EFL1 locks

- When applying a Multi Output Terminal: connect the AMP plug (1) to the output of the output extender.