

Pocket Door Framing Kit Futura

1) Preparation of the rough opening:

- Make sure rough opening is level and square. Frame the rough opening based on the following parameters:
 - Rough opening width 'A':
 - Calculation for a single pocket sliding door is $A = 2 \times \text{door width} + \text{min. } 1" (25.4 \text{ mm})$.
 - Calculation for a bi-parting pocket sliding door is $A = 4 \times \text{door width} + \text{min. } 1/2" (12.7 \text{ mm})$.
 - Rough opening height 'B':
 - a. For kits using **HAWA Junior 40/Z** fittings: $B = \text{door height} + 5 \frac{3}{16}" (132 \text{ mm})$.
 - b. For kits using **HAWA Junior 80/Z** fittings: $B = \text{door height} + 5 \frac{3}{4}" (146 \text{ mm})$.

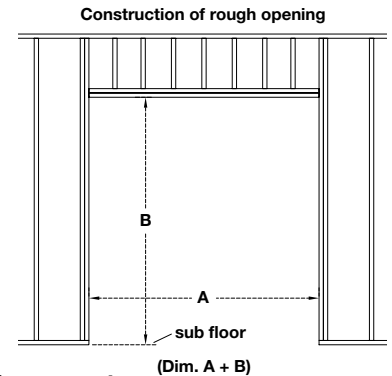

Diagram 1

2) Preparation of the header assembly:

- Header assembly is pre-manufactured for either 36" or 48" wide doors.
 - Other standard door sizes are marked on the 36" header assembly in the following increments (24", 28", 30", 32", 36").
 - Odd door widths have to be measured off.
 - If necessary, cut header to the appropriate size on left and right.
- Caution: Make sure that you cut the header assembly at the appropriate marks. The cutting points on the door side of the header assembly are different for a single pocket sliding door application in contrast to a bi-parting pocket sliding door application. On the pocket side of header assembly the cutting points are identical.
- Pre-drill header in 3 spots: front, center, back (**see diagram 2**).
- Determine the height, dimension "C" (**see diagram 3**), which provides the location of the header assembly based on the following chart.

Door Height	Dimension C-HAWA Junior 40/Z	Dimension C-HAWA Junior 80/Z
80" (6'8") (2032 mm)	83 9/16" (2123 mm)	84 1/8" (2137 mm)
84" (7'0") (2134 mm)	87 9/16" (2225 mm)	88 1/8" (2239 mm)
96" (8'0") (2438 mm)	99 9/16" (2529 mm)	100 1/8" (2543 mm)

- Odd door heights have to be calculated (e.g. customer is using an 82" tall door in combination with the framing kit and the HAWA Junior 80/Z sliding door fitting set. Based on these parameters, dimension C is calculated as follows: Height difference between standard door size shown in chart and actual door size is $82" - 80" = 2"$. Dimension C from chart for an 80" tall door is $84 \frac{1}{8}"$. New dimension C = $84 \frac{1}{8}" + 2" = 86 \frac{1}{8}"$).
- Measure up from the finished floor, using one of the selected or calculated dimensions and mark the spots.
- Use a square and run a line across the stud at the marked location.
- Mount the header assembly to the top structure of the rough frame at the pre-determined location using appropriate mounting screws (not supplied by Häfele). The mounting screws should be countersunk into the header assembly.
- Make sure the header assembly is mounted square to the studs and shim accordingly to make level across the opening.
- If using bi-parting doors, attach joining plate kit to both header assemblies (**see diagram 4A**).

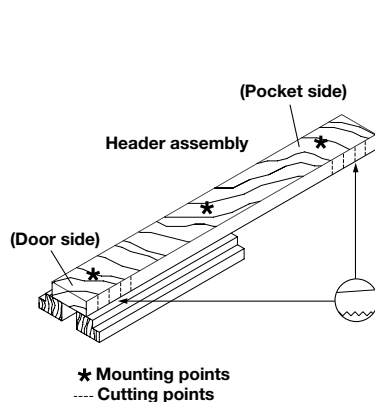

Diagram 2

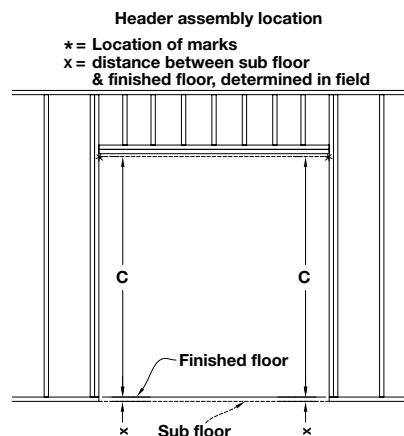

Diagram 3

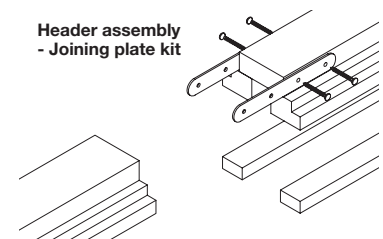

Diagram 4A

3) Preparation of the Upper Track:

- Cut upper track to the length of the header assembly.
- Insert Running gear and track stopper with retention spring into upper track.
- Make sure track stopper faces correct direction, tension spring should face towards pocket (**see diagram 4B**).
- Mount upper track to underside of header assembly using provided screws. (Pan head 4.5 x 25 mm, steel, zinc-plated)

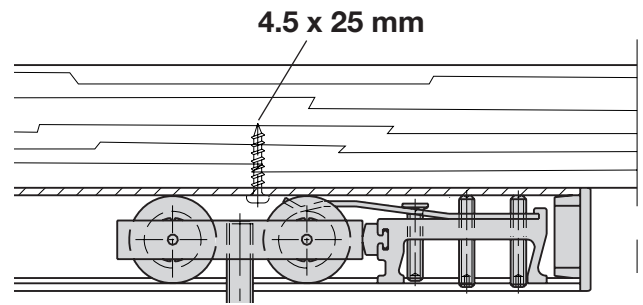

Diagram 4B

4) Preparation of floor plates and vertical steel studs:

- Snap a chalk line to assist in determining where to attach the floor plates (**see diagram 5**).
- For a standard 2 x 4 stud wall, assemble the front and back floor plates in such a way that the 90 mm dimension that is imprinted on the plates is shown at the marker. Make sure front floor plates line up precisely with mid-portion of header assembly. Attach the floor plates to sub-floor with provided screws (pan head, 4.5 x 25 mm, steel zinc-plated). Position back floor plates half the distance behind or at a maximum of 16" (CTC) and attach with provided screws. (Pan head 4.5 x 25 mm, steel, zinc-plated)
- Measure the height of the vertical steel studs and cut to size, if necessary.
- Note: when cutting to size, back steel studs are universal, however make sure you have a left and right for the front steel studs. Cut steel studs at the bottom. The top of the steel studs is indicated by the pre-drilled holes.
- Slide bottom portion of steel stud over nibs on pre-mounted floor plates and screw top portion to side of header assembly (**see diagram 6**).

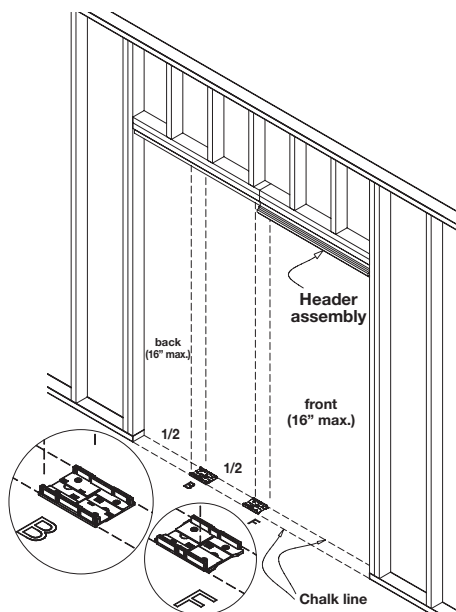

Diagram 5

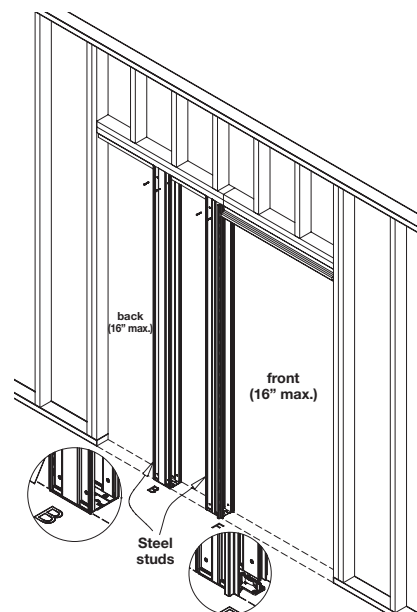
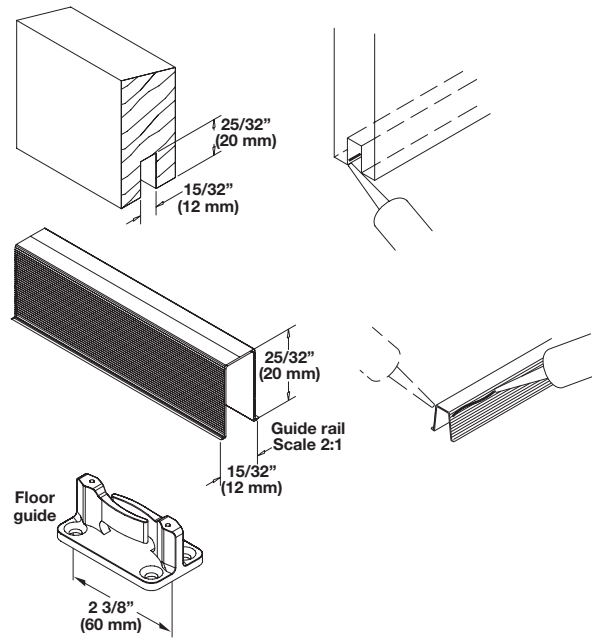
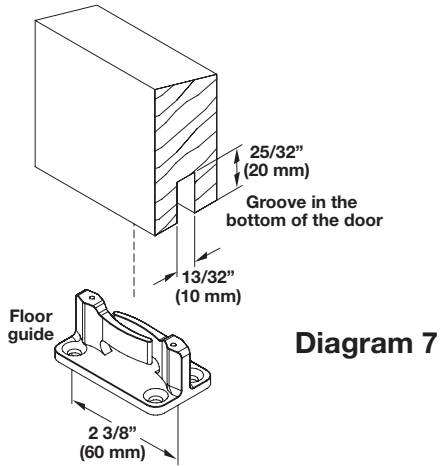

Diagram 6

5) Preparation of floor guide:

- If not pre-fabricated, cut a groove in the bottom of the sliding door.
 - For solid core doors, cut a groove that is $13/32"$ x $25/32"$ (10 x 20 mm). **(see diagram 7).**
 - For anything other than a solid core door, we recommend using the guide rail in conjunction with the floor guide. You will need a slightly larger groove of approximately $15/32"$ x $25/32"$ (12 x 20 mm) to glue in the optional guide rail (Cat # 940.41.130) in the door **(see diagram 8).**



- Depending on the height of the finished floor, you may need to add a block of wood under the floor guide to accommodate appropriate spacing **(see diagrams 18 and 19)**. Mount the floor guide to the bottom opening of the pocket **(see diagrams 9 and 10)**.

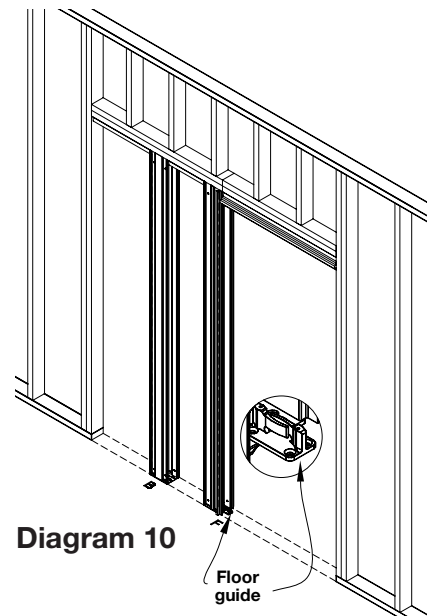
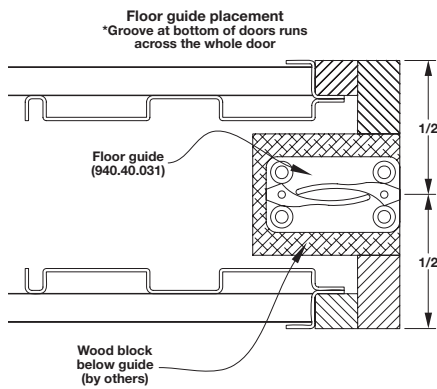

6) Door installation:

- Attach the suspension plate to the top of the door. Spacing is as follows: **(see diagram 11)**
 - HAWA Junior 40 is 3 3/4" from edge of the door.
 - HAWA Junior 80 is 5 1/8" from edge of the door.
- Thread the suspension bolt into the running gear.
- Hang the door off the running gear/suspension bolt.
- Adjust door height using the height adjustment pin and tighten the locking nut **(see diagram 12)**. You should slide the door to test the operation before making final adjustments
- Screw the bumper to the back edge of the door or the wood stud inside the pocket, approximately 40" up from the floor **(see diagram 13)**. Slide door into pocket in order to make sure that the front edge of the sliding door lines up with the finished split jamb. In case the door sticks too far into the pocket, add a wood spacer between the bumper and the wood stud (refer to the plan view).

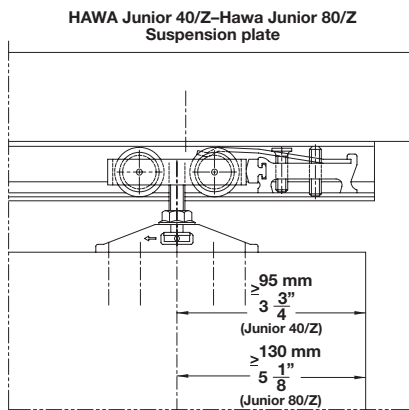

Diagram 11

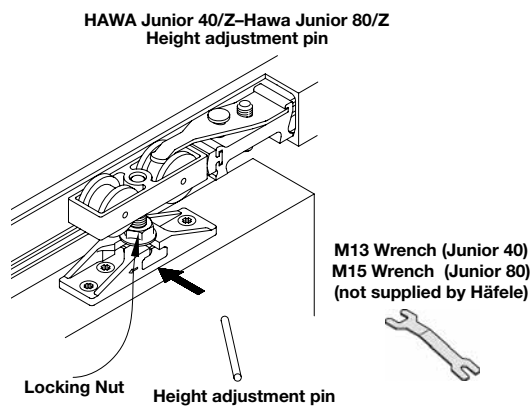

Diagram 12

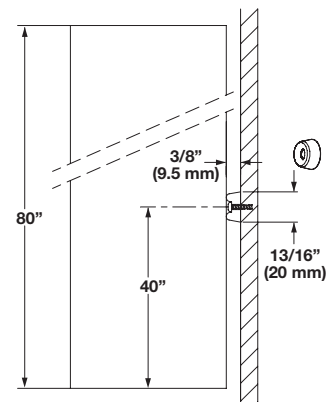

Diagram 13

7) Installation of the filler strips:

- The filler strips are used to fill the gap between the header assembly and the finished split jamb (not supplied by Häfele).
- Cut the filler strips to size.
- Pre-drill and attach the filler strips to the underside of the header assembly with provided fastening screws (flat head, 3.5 x 30 mm, steel, zinc-plated).
- Important: Leave one side removable for accessibility after installation is complete **(see diagram 14)**.

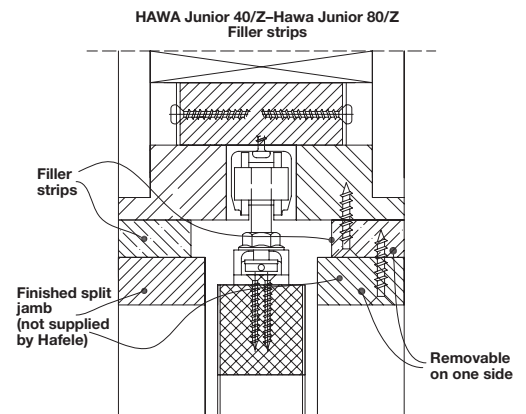

Diagram 14

8) Finish Installation:

- Drywall the pocket using provided self-tapping fixing screws (flat head, 4.2 x 19 mm, steel, zinc-plated).
- Mount finished split jamb and finished jamb (not supplied by Häfele).
- Mount finished split header (not supplied by Häfele).
- Important: Leave one side removable for accessibility after installation is complete **(see diagram 14)**.

POCKET DOOR DIMENSIONS
 FOR HAWA JUNIOR 40/Z AND HAWA JUNIOR 80/Z
 BASED ON STANDARD DOOR SIZES

15

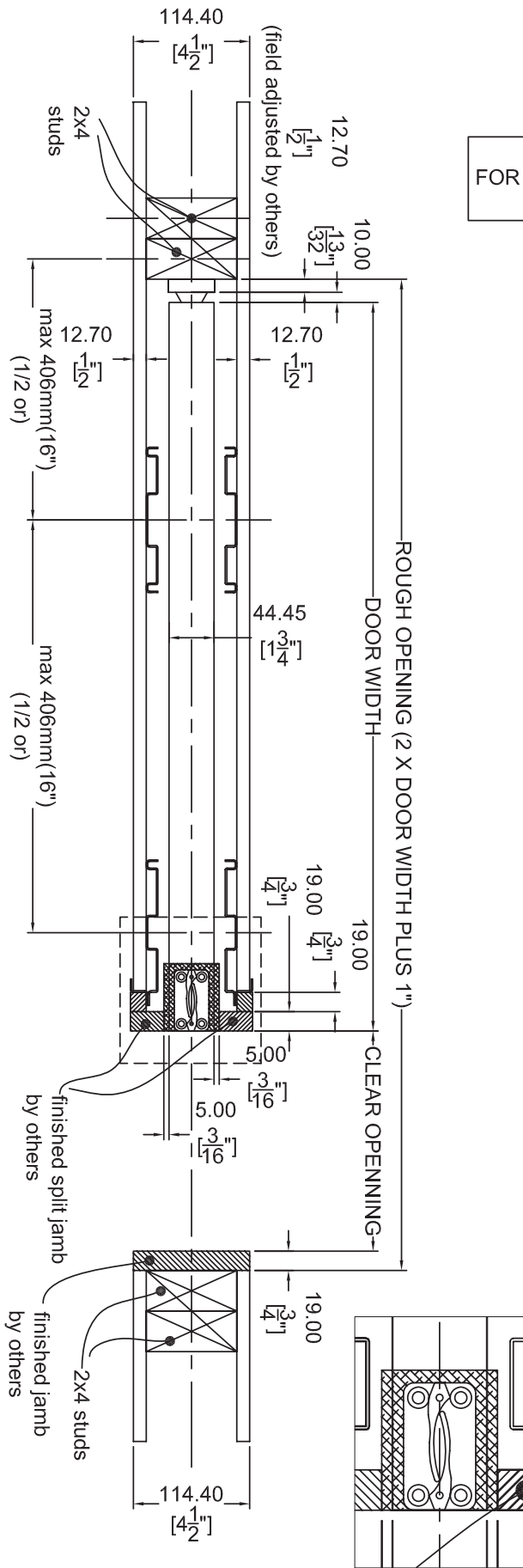

Häfele Futura Pocket Door Kit
Hawa Junior 40/Z
Type I

16

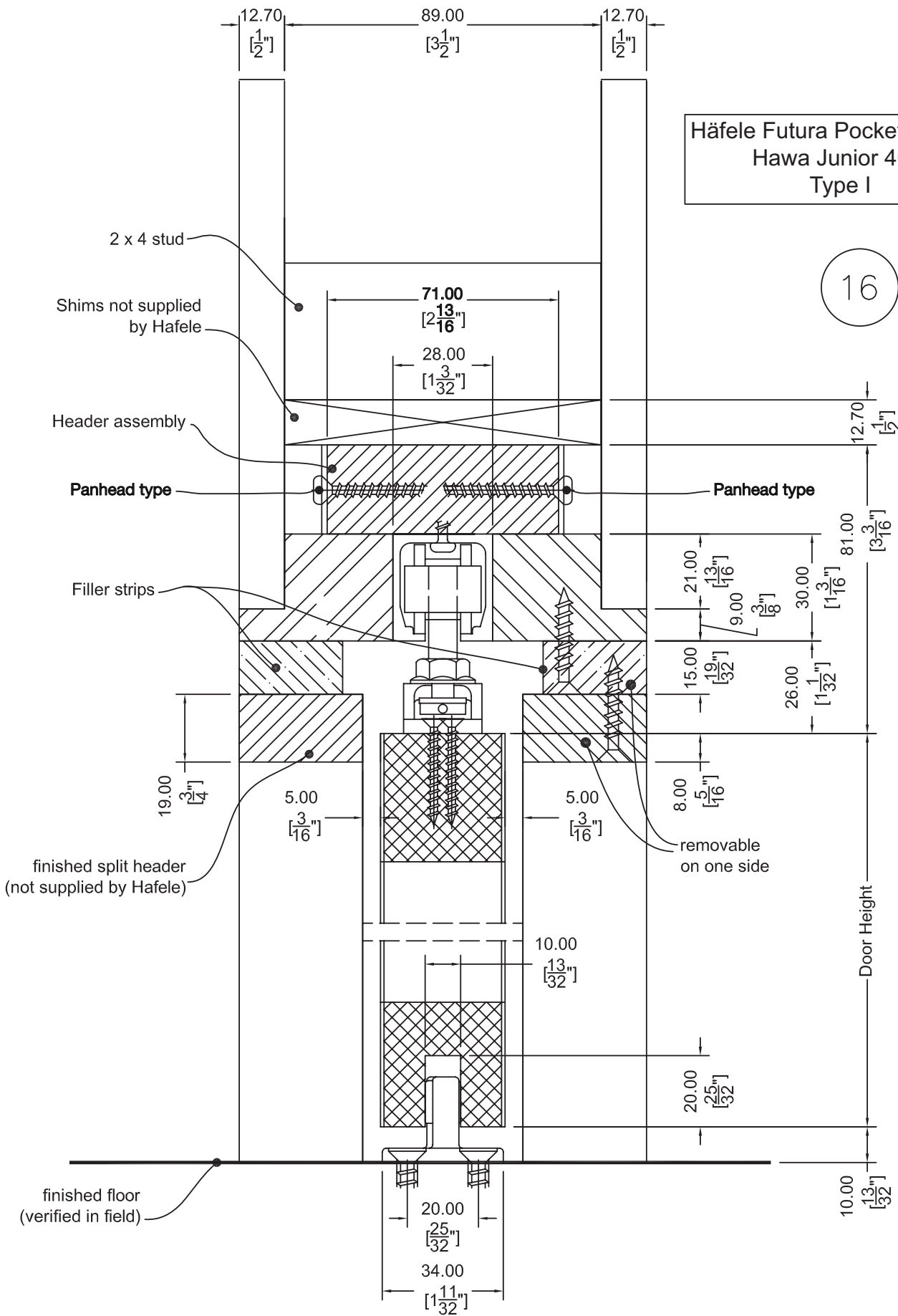

Häfele Futura Pocket Door Kit
Hawa Junior 80/Z
Type II and III

17

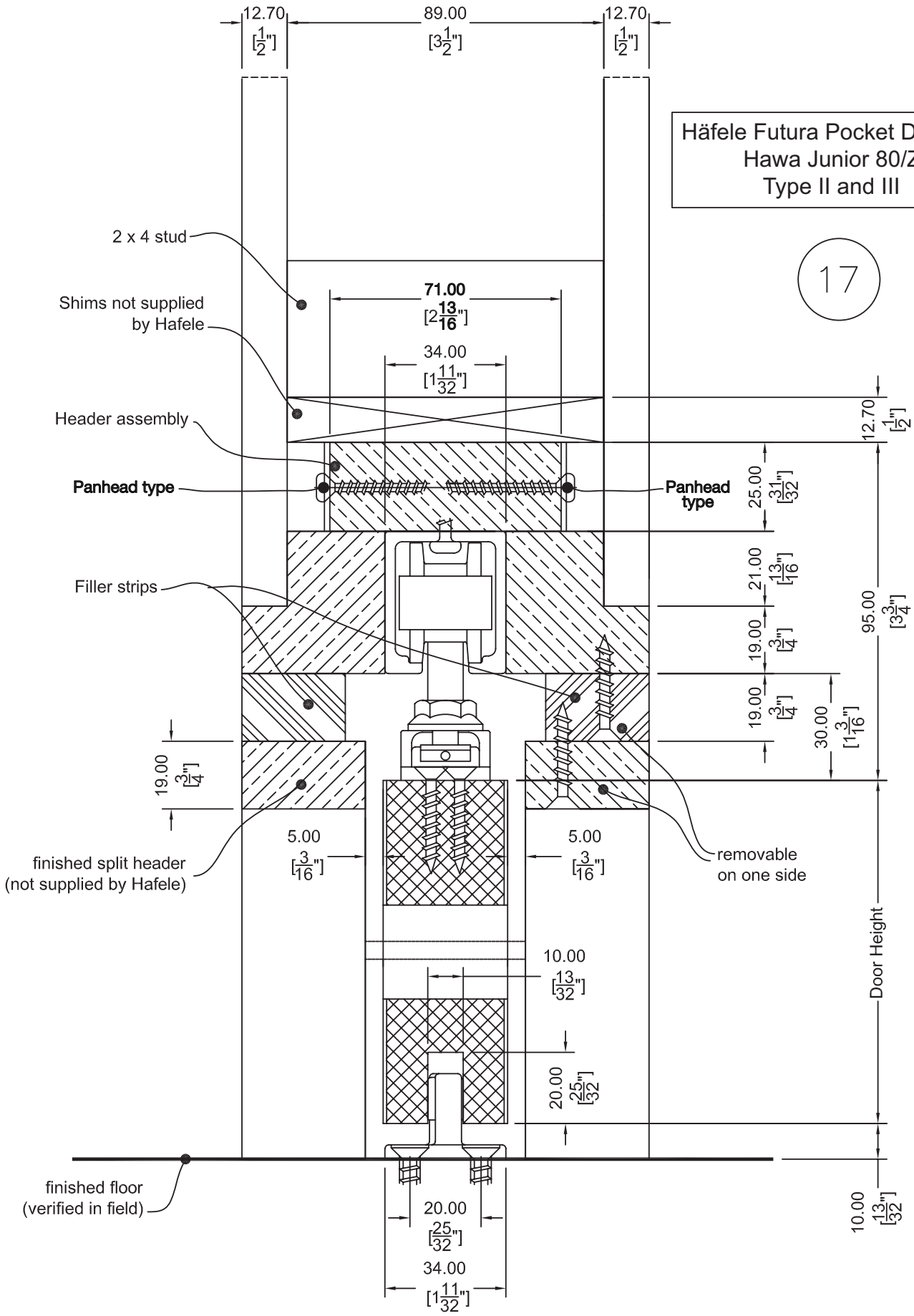

Hafele FUTURA Pocket Door Kit
Hawa Junior 40/Z
Type I
with view of subfloor

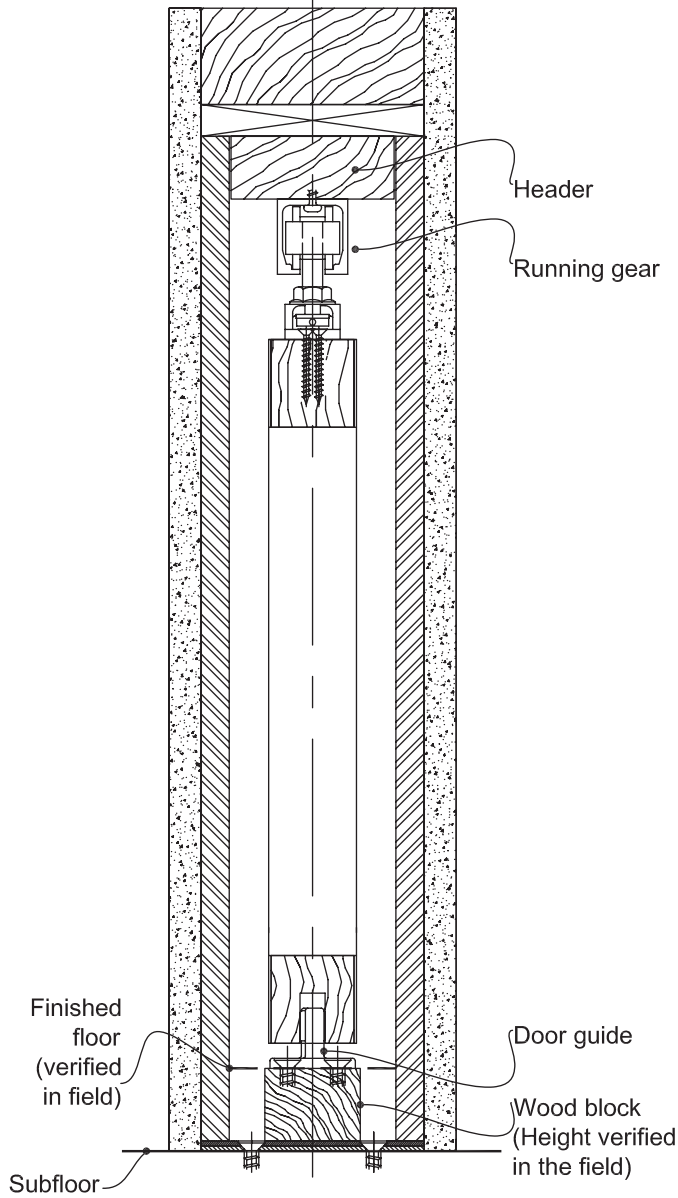

18

Hafele FUTURA Pocket Door Kit
Hawa Junior 80/Z
Type II and III
with view of subfloor

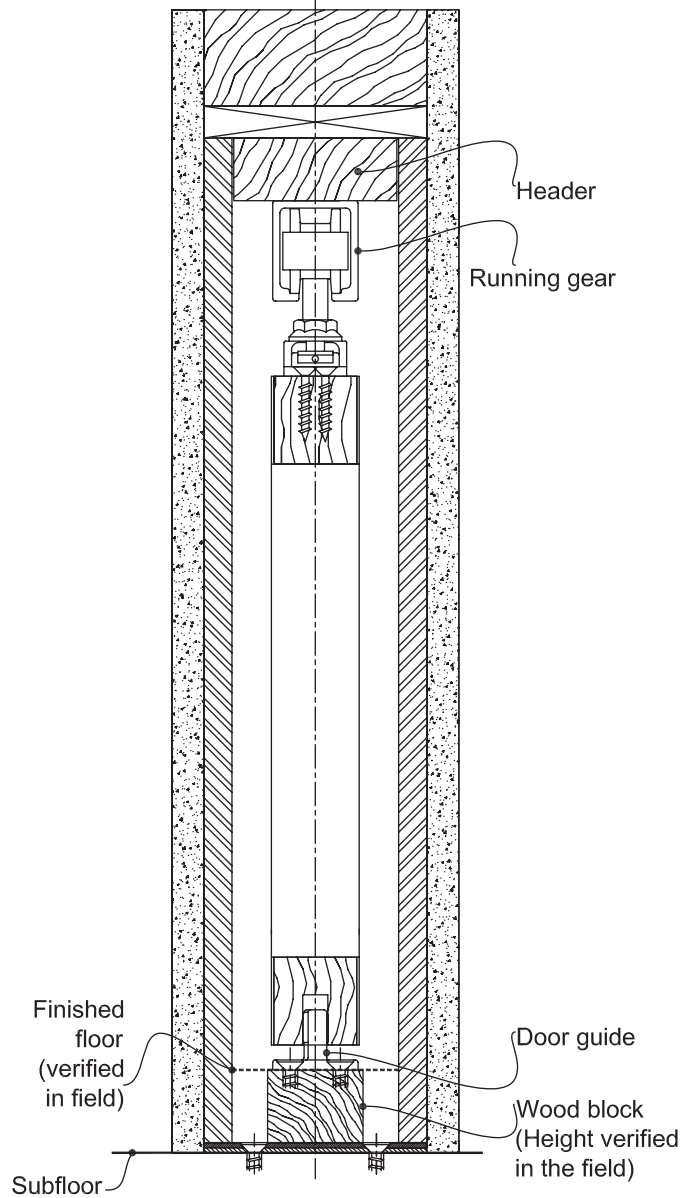

19

HÄFELE

3901 Cheyenne Drive

P.O. Box 4000

Archdale, NC 27263

1-800-423-3531

www.hafele.com