

Item No.: 271.97.301

Hiddenbed Double

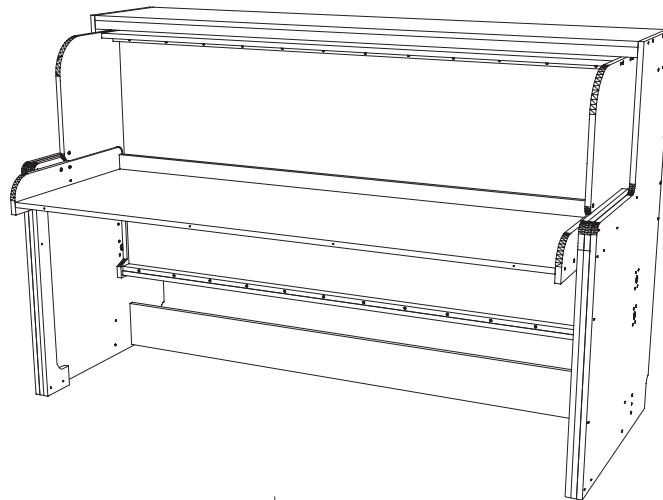
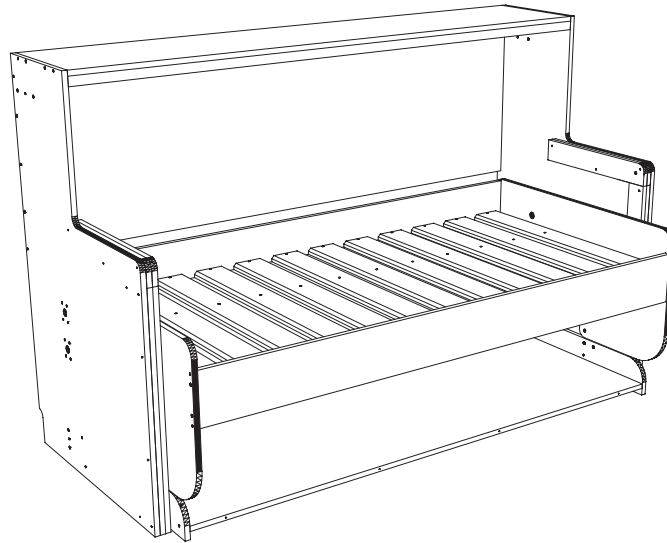

Follow these steps to assemble your Hiddenbed

- 1** Construct the 3 main parts **2** Assemble them together

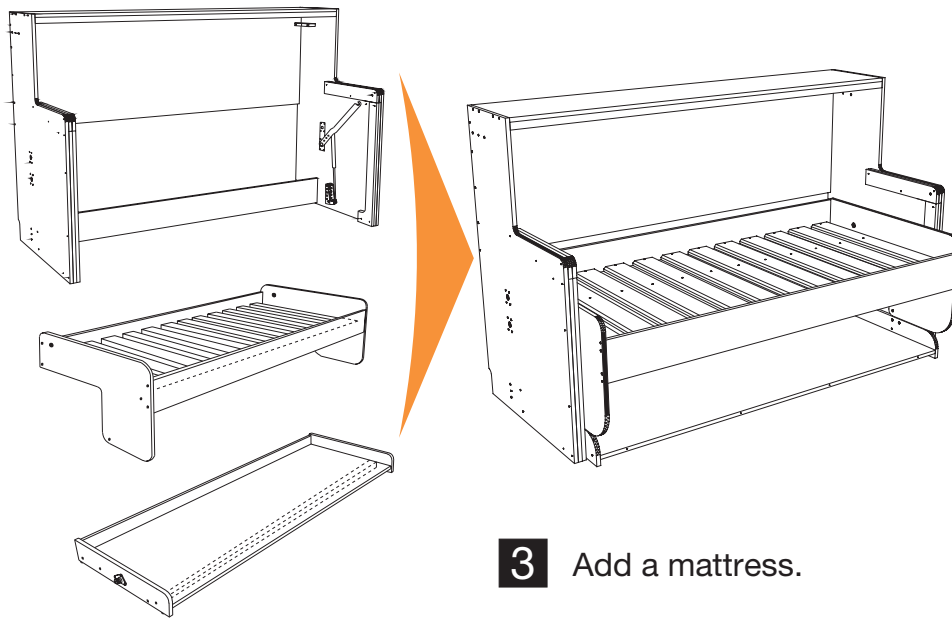

YOUR HIDDENBED IS READY!

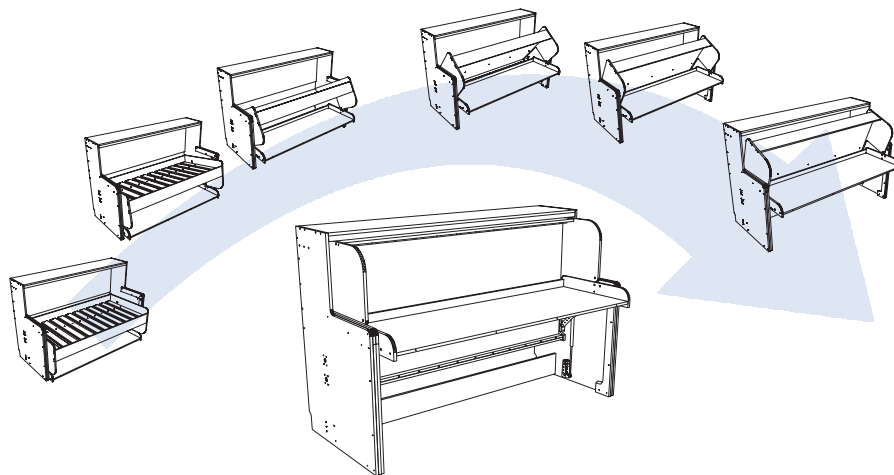

Parts List

Body Parts			
Part No.	Name	Qty	Pg
1	Body Side L/R	2	1
2	Body Side Concealer	2 sets	2
3	Bottom Stretcher	1	3
4	Body Top	1	4
5	Top Stretcher	1	5
6 (*)	Top Stiffener/Metal	1	-
7	Body Back	1	7
18	Bed Stop	2	18

* See item No.: 940.84.253

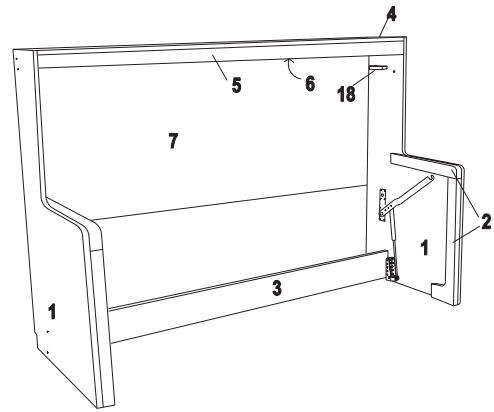

Bed Parts			
Part No.	Name	Qty	Pg
8	Bed head L/R	2	8
9	Slats Cover Sheet	1	9
10	Front Bed Rail	1	10
11	Rear Bed Rail	1	11
12	Bed Slats/Solid Wood	12	12
13	Slats Cleats	2	13

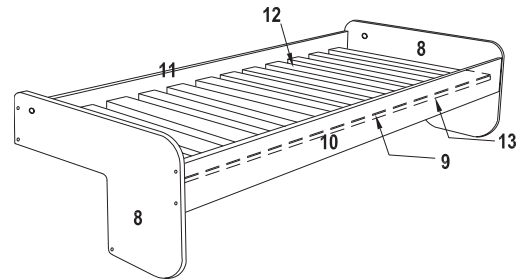





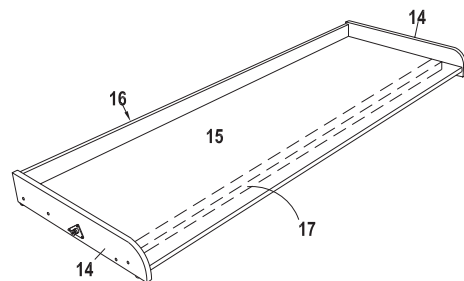

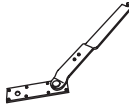

Desk Parts			
Part No.	Name	Qty	Pg
14	Desk Side L/R	2	14
15	Desk Top	1	15
16	Desk Back	1	16
17(*)	Desk Stiffener /Metal	1	17

* See item No.: 940.84.253

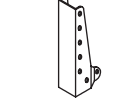
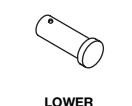

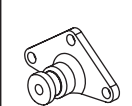

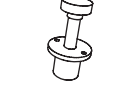

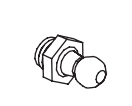

Component List

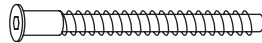

Mechanism Kit – Item No. 271.97.301

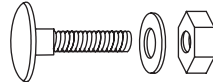
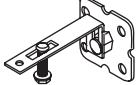
 <p>A1 MECH ARM PLATE 2 pcs.</p>	 <p>A2 GAS SPRING 2 pcs.</p>	 <p>A3 LOWER SUPPORT 2 pcs.</p>	 <p>A4 LOWER SUPPORT PIN 2 pcs.</p>	 <p>A5 COTTER PIN 2 pcs.</p>	 <p>A6 TRIBEARER 2 pcs.</p>	 <p>A7 LINK PIVOT 2 sets</p>
 <p>A8 TRUNNION BUSHING & SCREW 2 pcs.</p>	 <p>A9 LOCKING PIN WITH SCREWS 2 pcs.</p>	 <p>A10 LOCK BUSHING 4 pcs.</p>	 <p>A11 PIN BALL 2 pcs.</p>			

Hardware Kit – Item No. 450.19.400

	H2, 7x70, Conformat	59
	H14, #8 x 1 1/2", Flat Head Wood Screw	22
	H10, #8 x 2", Flat Head Wood Screw	46
	H9, #8 x 3/4", Flat Head Wood Screw	7
	H6, 1/4" - 20 x 2", Flat Head Allen & T nut	6
	H3, 1/4" - 20 x 1 1/4", Carriage Bolt, Washer & Nut	20
	Safety Bracket	2
	Bumper, 10 x 20 mm	2

Shelf Stiffener Kit – Item No. 940.84.253

	Aluminum Stiffener for Body Top, 2035 mm Long	1
	Aluminum Stiffener for Desk Top, 1909 mm Long	1
#8 x 5/8", Pan Head Screw for Attachment		18

IMPORTANT POINTS FOR SAFE AND RELIABLE OPERATION

Make sure that:

- Unit is leveled; that both side panels are parallel and level.
- Unit needs to be properly secured to the wall, see Häfele Item 271.98.100 safety brackets (included in assembly hardware kit #450.19.400)
- Stand at the middle when moving from bed to desk positions.
- Keep fingers clear from closing parts.

For best performance:

- Use a mattress with an approximate weight of 55 lbs (25 kgs) and a maximum height of 12".
- Items placed on desk, should not exceed 55 lbs (25 kgs).
- Use position "C" for upper pin.
- Using the above criteria, the effort to move from desk to bed positions should take approximately 20 lbs. of force.
- Avoid excessive or off-center loads on desk.
- Items left on desk cannot exceed 20" in height and 55 lbs. in weight.
- Avoid trapping fingers in closing parts.
- Use the locking pins to "lock" into desk or bed positions.
- Make sure that electrical cords do not get pinched in any pivot points.
- Pivot points should be periodically lubricated with WD-40 or similar.



Use the Locking Pins on Desk Side to lock in place in both bed and desk positions.



In general 2 people are required to assemble and install this product.

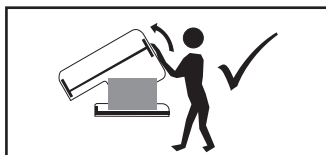
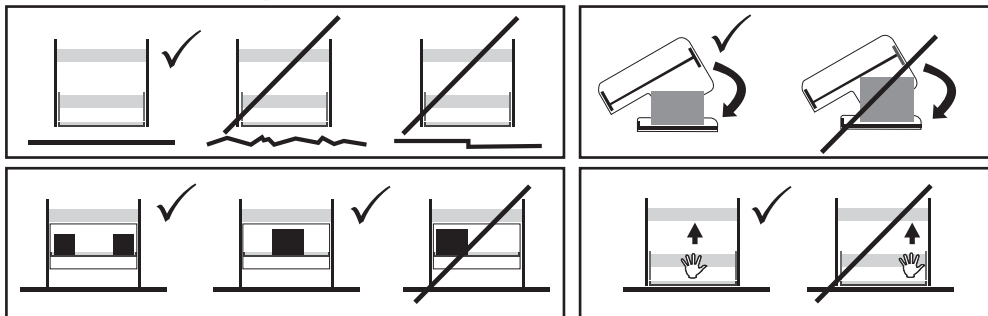

WARNINGS

Successful and safe installation of fitting set and construction of bed requires a professional skill level. CNC equipment for panel processing and accurate hole locations is mandatory; both vertical and horizontal holes are required. MDF board is required as opposed to particleboard to ensure structural integrity.

Body Assembly

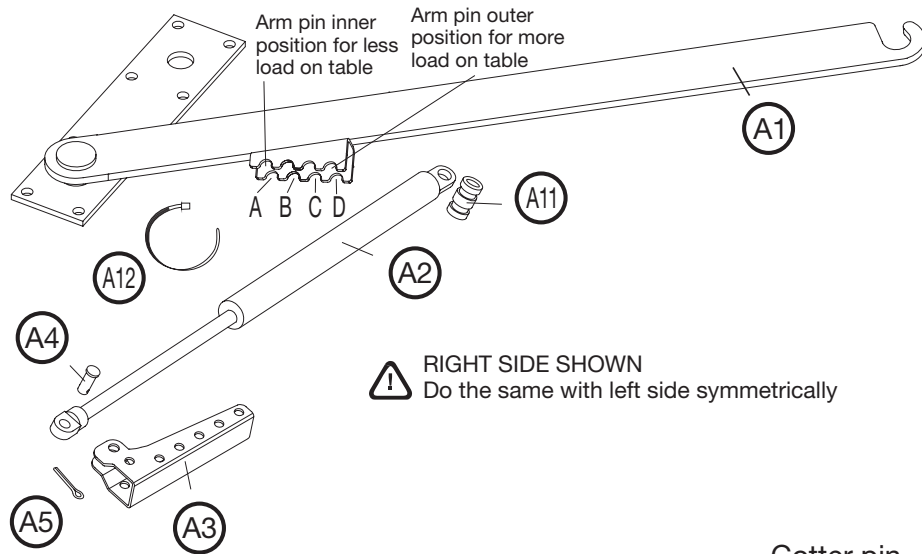

Cotter pin

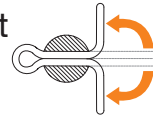

- 1** Attach blade side of gas spring to lower support (A3) using lower support pin (A4), insert cotter pins (A5) and bend ends.
- 2** Attach arm plate (A1) to body side using 8 sets carriage bolts, washer and nuts. Make sure the hook on arm is facing upwards.
- 3** Attach lower support (A3) to body side using 2 sets carriage bolts, washer and nuts. Repeat steps above for opposite side.
- 4** Place the upper Pin (A11) in the Gas Spring Blade. Place the gas spring (A2) in the arm crest (A1) using the upper pin (A11). Then fix the gas spring to the arm using the plastic fastener (A12).

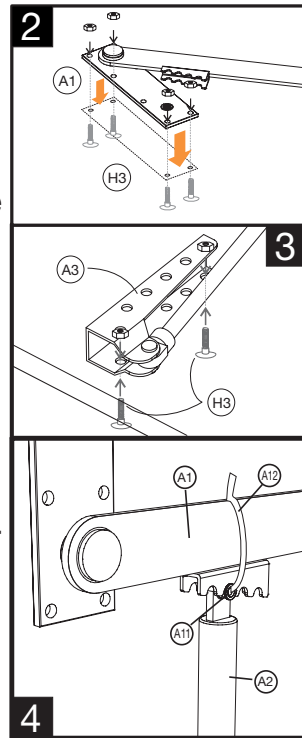
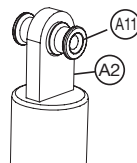

- 5** Attach bed stops (18) to body sides (1) using 2 pcs. Confirmat screws per side (H2).

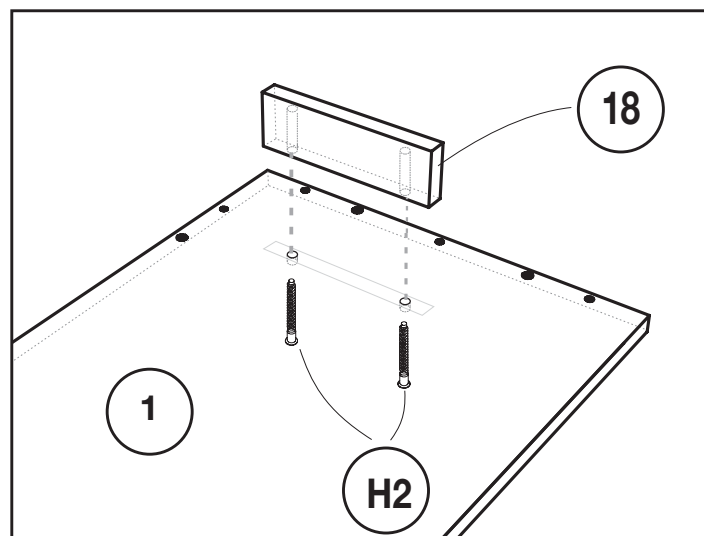

- 6** Attach top stretcher (5) to body top (4) using 6 pcs #8 x 1 1/2" wood screws. Attach metal top stiffener (6) 2035 mm long under body top, directly behind top stretcher using 6 pcs . repackaged #8 x 5/8" long pan head screws (H14). Additional holes may have to be drilled in the aluminum profile to accept screws.

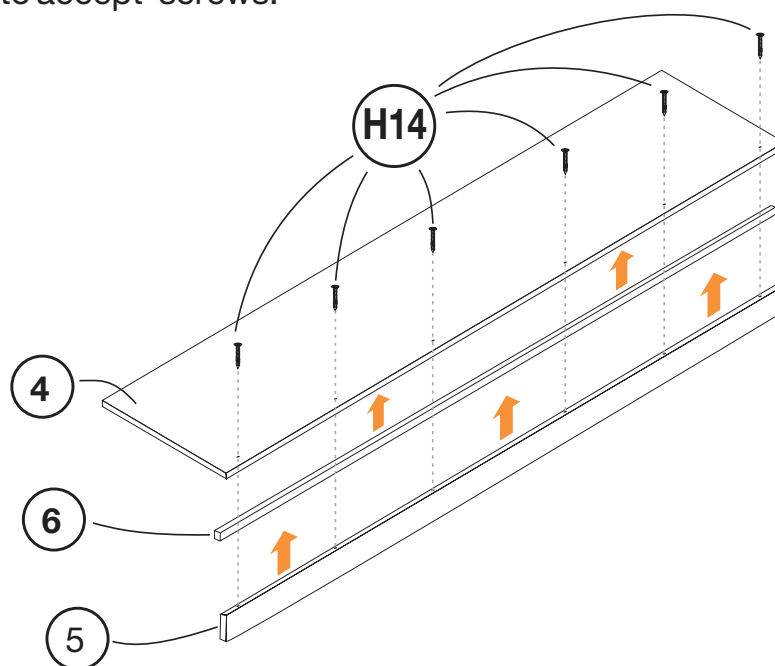

7 Assemble body sides (1), body top (3), body back (7), and bottom stretcher using Confirmat screws (H2, 28 pcs.).

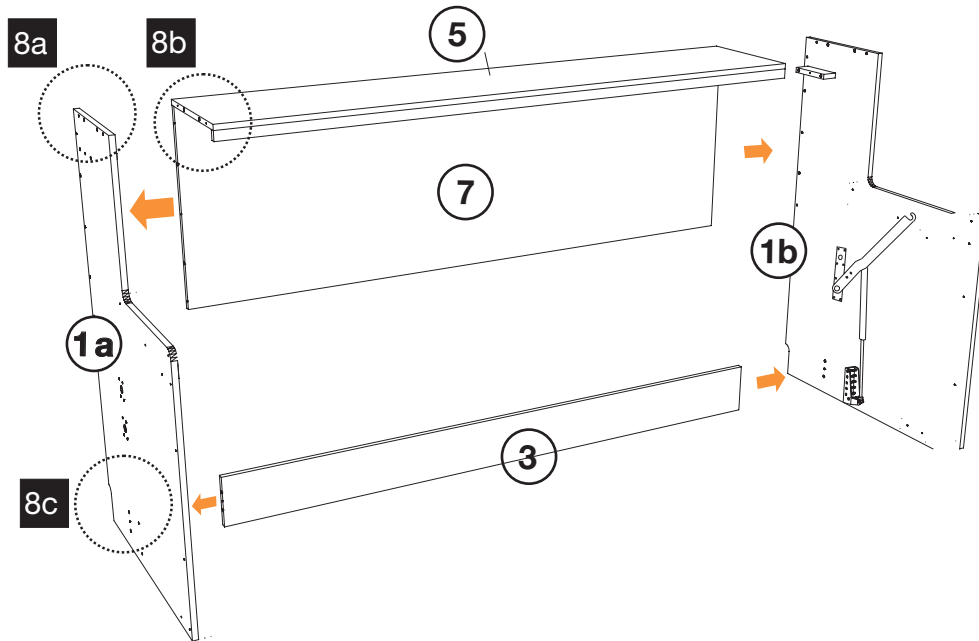
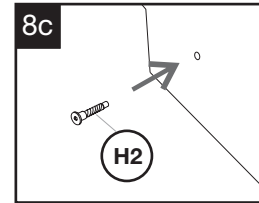
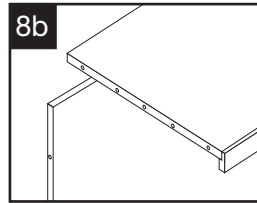
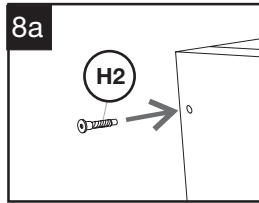

Desk Assembly

- 1 Attach desk back (16) to desk top (15) using 4 pcs. Confirmat screws (H2).

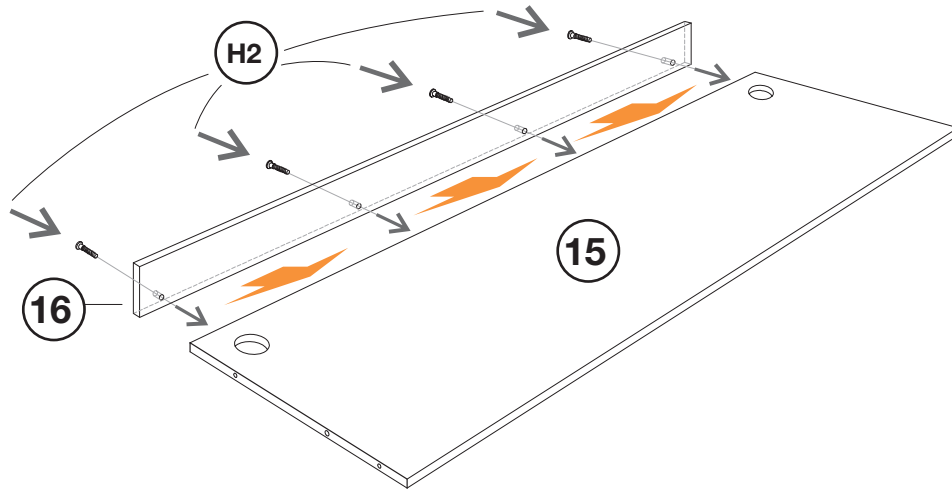

- 2 Attach the tribearer (A6) to desk sides (14) using 3 pcs. Flat Head & T nut (H6) and 1 pc. #8 x 3/4" (H9) on top hole of tribearer.

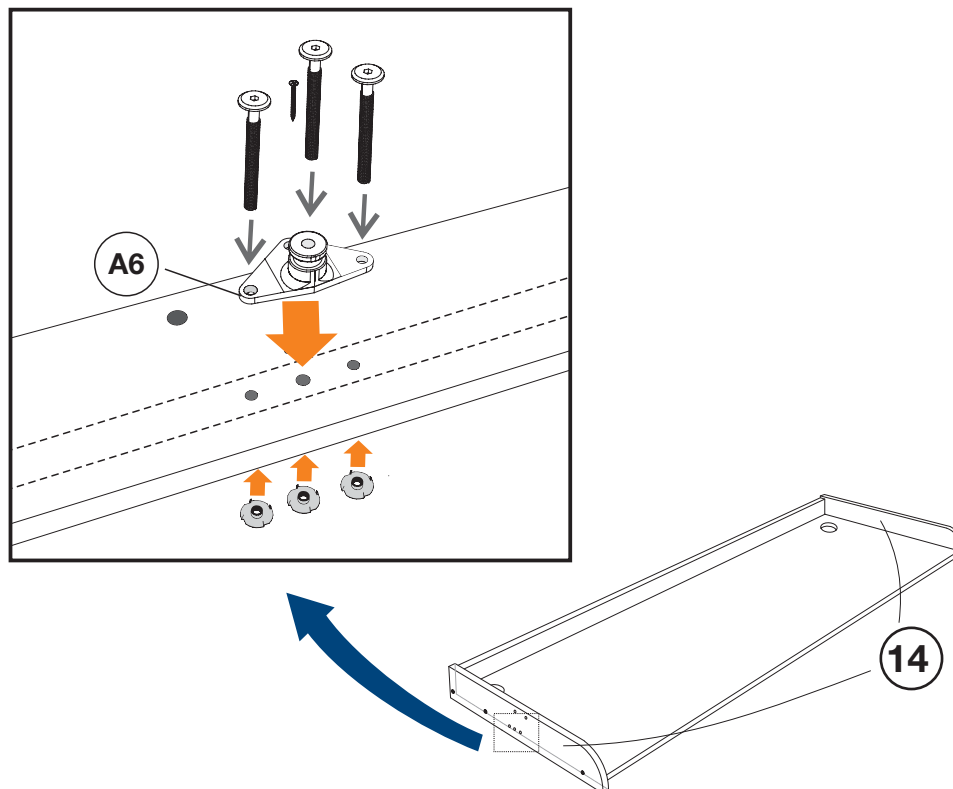

- 3** Attach sides (14) to desk top (15) using 8 pcs. Confirmat screws (H2).

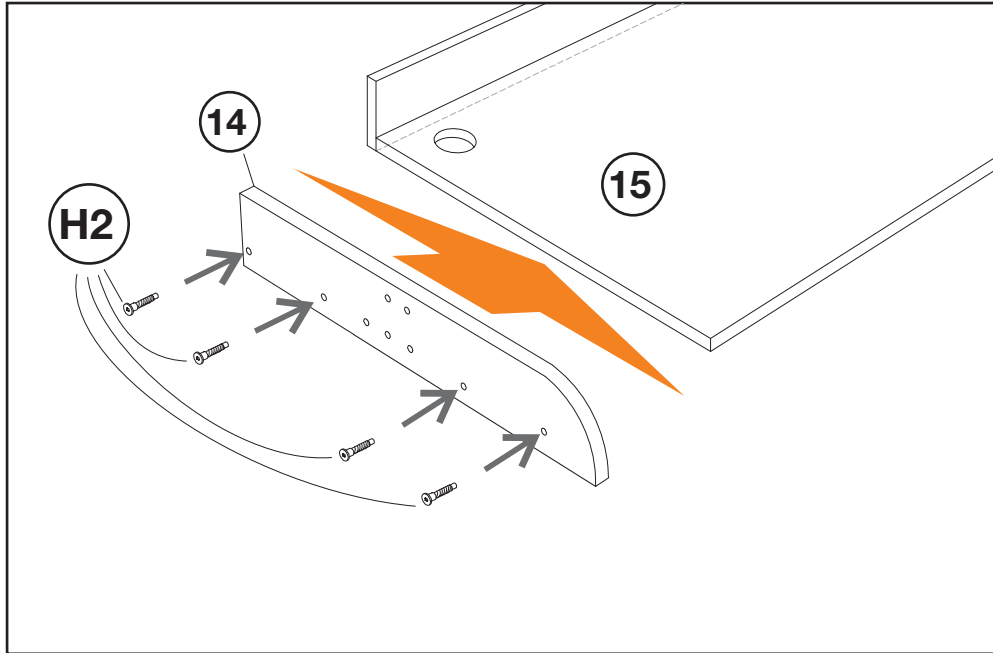

- 4** Attach metal top stiffener (17) 1909 mm long under desk top approximately 6" from front edge using 6 pcs. re-packaged screws #8 x 5/8" long pan head screws. Additional holes may have to be drilled in the aluminum profile to accept screws.

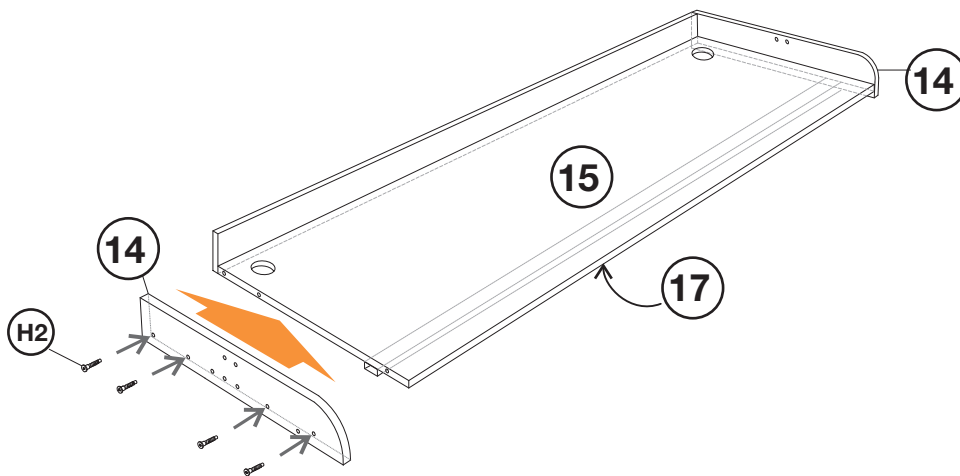

Bed Assembly

- 1 Attach front bed rail (10) and rear bed rail (11) to bed heads (8) using Confirmat screws (H2). Make sure that holes for affixing bed cleats are facing the right direction, see technical drawings indicating bottom sides.

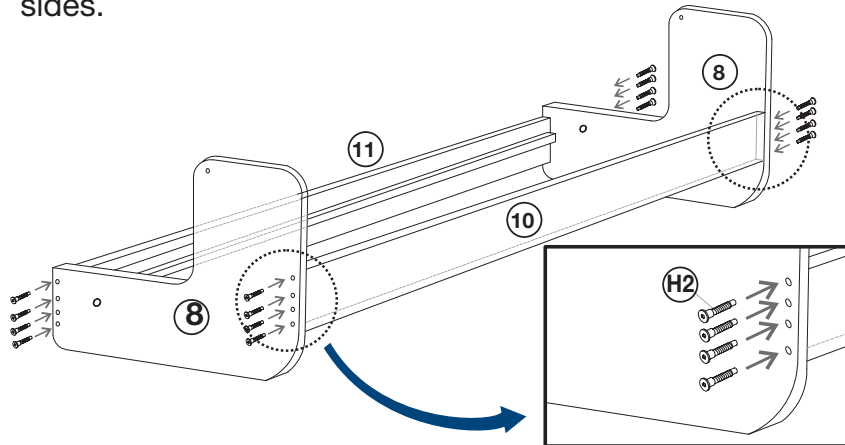

Attach slat cleats (13) to bed rails using #8 x 1 1/2" flat head screws (H14). Make sure that pilot holes for bed slats are facing up (down in sketch position)



Do not attach slats cover or bed slats at this point, they must be attached after bed and body is assembled together.

Final Assembly

- 1 The link pivot sets (A7) come assembled together. Un-screw and remove the plate from one side.

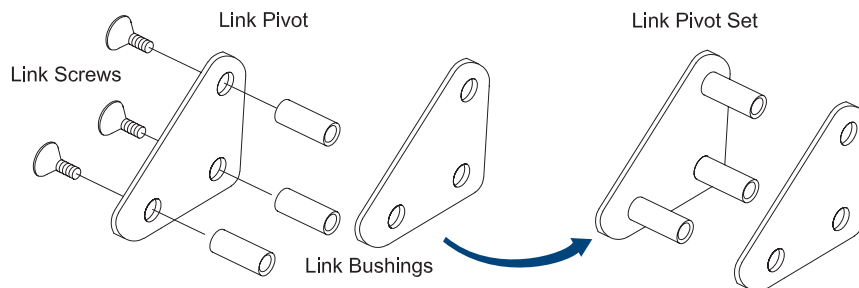

- 2** Place the bed head assembly on top of desk top assembly as shown below, and align holes for link pivot - see detail 2 below.
From the outside introduce the link pivot into holes as shown, slightly raising the bed assembly to align holes.

 **HEAVY - BE CAREFUL**

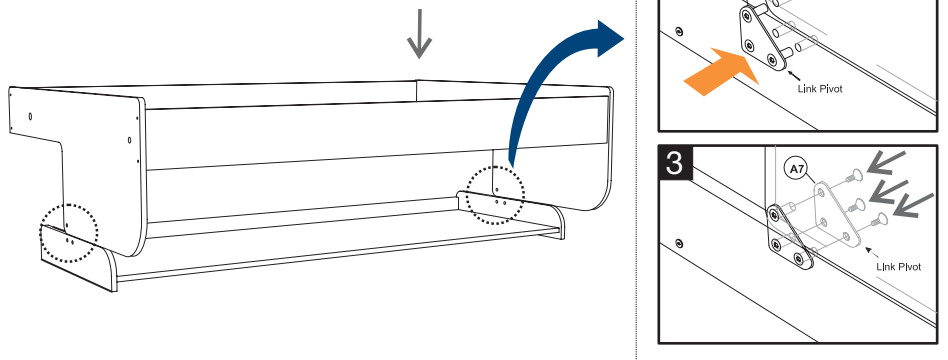

- 3** Attach other plate onto the link pivot securely with remaining screws. Make sure all screws are tight.

- 4** Slide the body assembly over the bed assembly taking caution that the arm mechanism does not scratch the sides of body.
Align holes for trunion bushings (A8), install trunion bolt and loosely tighten until other side is aligned and affixed.
Strongly tighten both trunion bolts.

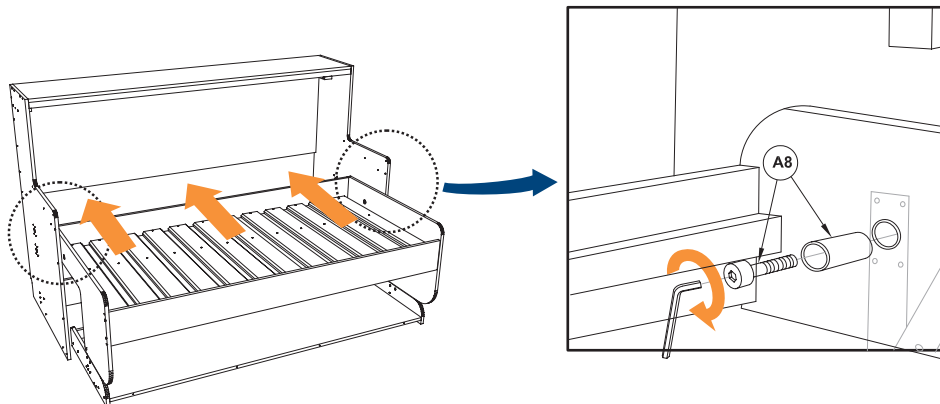

- 5** Place the 1/4" thick slats cover sheet (9) on top of slat cleats. Place bed slats (12) over cover sheet, align holes. Affix bed slats by driving screws through slats, through cover sheet and into bed cleats using 24 pcs. #8 x 2" flat head wood screws (H10)

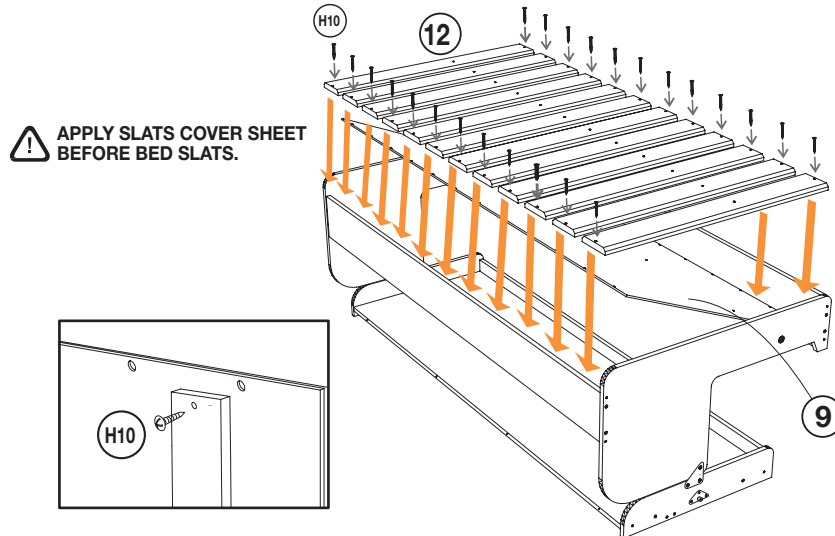

- 6** Attach the top portions of body side concealers only at this point using #8 x 2" flat head screws (H10) (the bottom parts are installed after arm mechanism is attached). Pound in lock bushings (A10) in both sides of upper side concealers. Install locking pins (A9) in desk sides with included black screws.

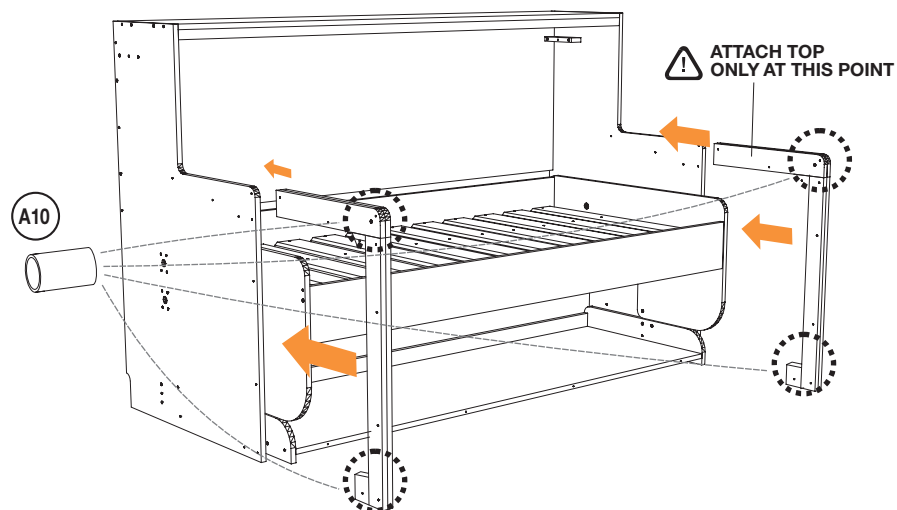

- 7** Carefully lift the bed slowly keeping the desk in horizontal position. Once in upper position, lock into place in both sides by pushing in the locking pins. Attach arm mechanisms to tribearer making sure it seats in the slot - see diagrams below.

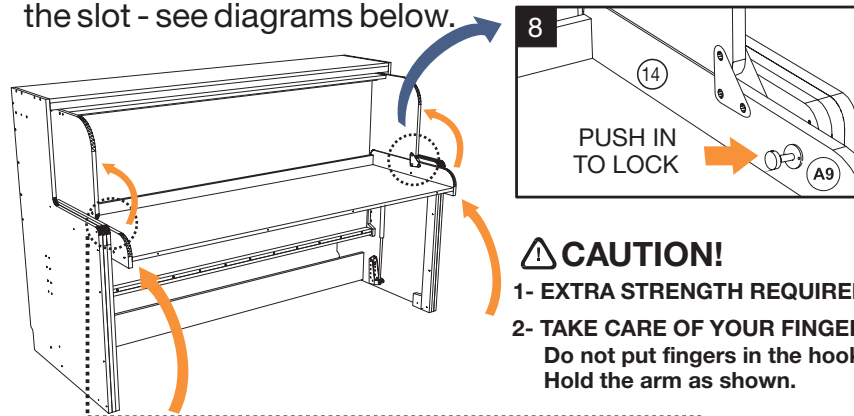

! CAUTION!

- 1- EXTRA STRENGTH REQUIRED
- 2- TAKE CARE OF YOUR FINGERS
Do not put fingers in the hook.
Hold the arm as shown.

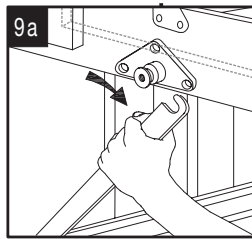

9a Slowly pull mech arm downwards.

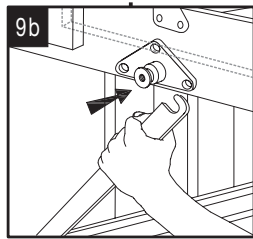

9b Gently push mech arm to the inner side of tribearer.

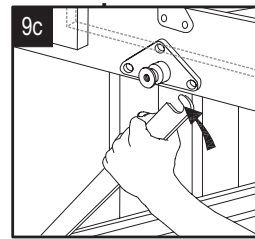

9c Slowly release mech arm upwards to engage the slot in tribearer.

Finish attaching bottom portions of body side concealers, install lock bushing for bottom locking position. Install rubber bumpers to bed stops using #8 x 1 1/2" flat head screws - be sure bumpers align with side of bed as it meets stops.

- 10** Be sure the unit is anchored properly to the wall. Use the safety brackets as shown below, making sure wall studs are used for attachment. Add mattress (not included).

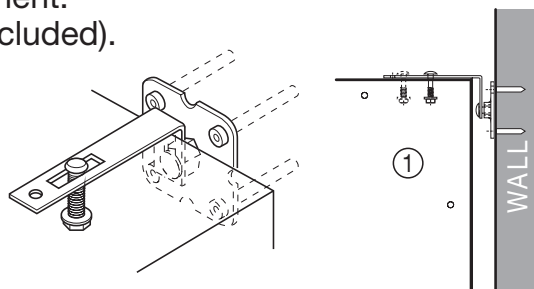

Operation

- Make sure unit is leveled and properly anchored to the wall.
- Make sure the floor is cleared when lowering the bed.
- Stand at the middle when moving from bed to desk positions.
- To move from bed to desk positions, first unlock pins on both sides, then grab front bed rail and slowly raise - be sure to keep fingers clear when reaching the top position.
- To move from desk to bed position, first unlock pins on both sides, then grab front bed rail with one hand and push down the desk with the other hand, be sure to lock in position again.
- For convenience a handle can be placed under bed (on slats cover sheet) to assist with moving from desk to bed.
- Hiddenbed system is based on a desk to bed balance. An unbalanced ratio may result in having to apply extra force when moving from bed to desk and vice versa.
- Pin arm position on arm (A,B,C) may have to be adjusted to properly assist load.

HÄFELE

3901 Cheyenne Drive

P.O. Box 4000

Archdale, NC 27263

1-800-423-3531

www.hafele.com