

- GB** Installation Guide
- D** Einbauanleitung
- F** Guide d'installation
- I** Guida all'installazione
- E** Guía de instalación
- S** Installationsanvisningar

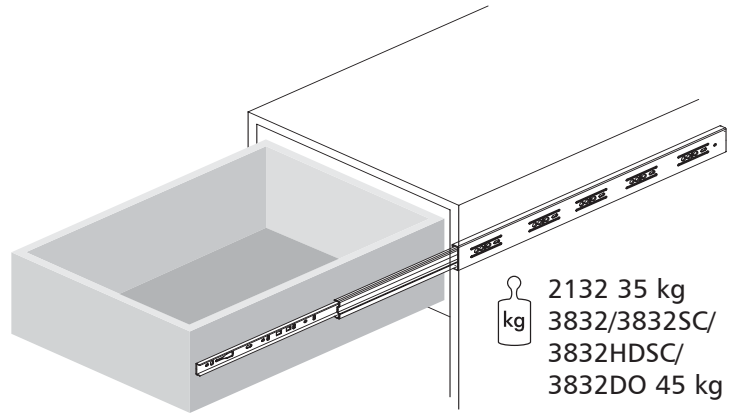

2132

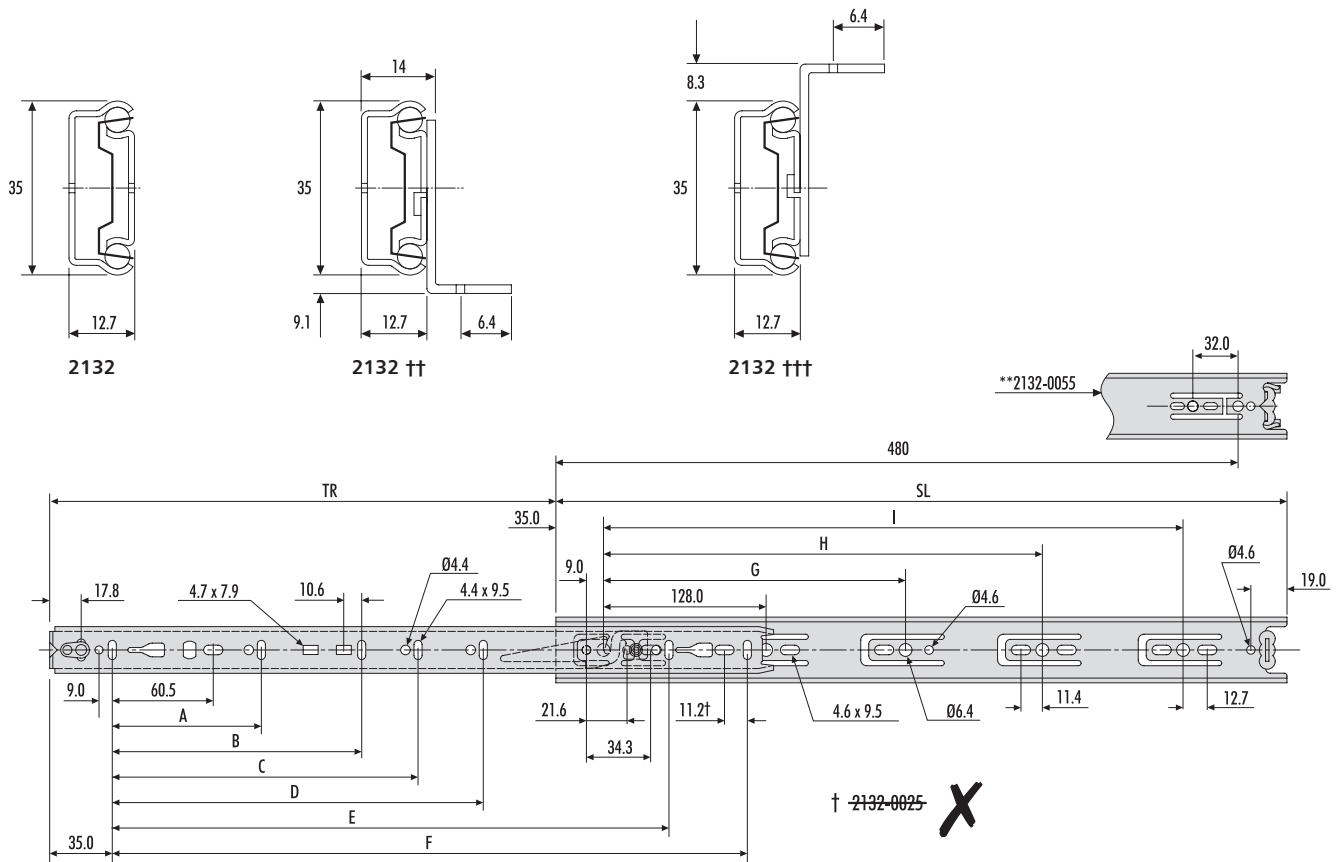

2132	mm										
	SL	TR	A	B	C	D	E	F	G	H	I
2132-0025	250	163	96	-	-	-	-	192	-	-	-
2132-0030	300	205	96	-	-	-	-	242	224	-	-
2132-0035	350	260	128	-	-	-	-	292	224	-	-
2132-0040	400	281	128	-	-	-	-	342	224	-	320
2132-0045	450	331	128	224	-	-	-	392	224	-	352
2132-0050	500	376	128	224	-	-	-	442	224	-	416
2132-0055	550	415	128	224	320	-	-	492	224	352	**
2132-0060	600	451	128	224	320	-	-	542	224	352	480
2132-0065	650	488	128	224	320	416	544	592	224	352	544
2132-0070	700	526	128	224	288	416	-	642	224	352	544

3832/3832DO

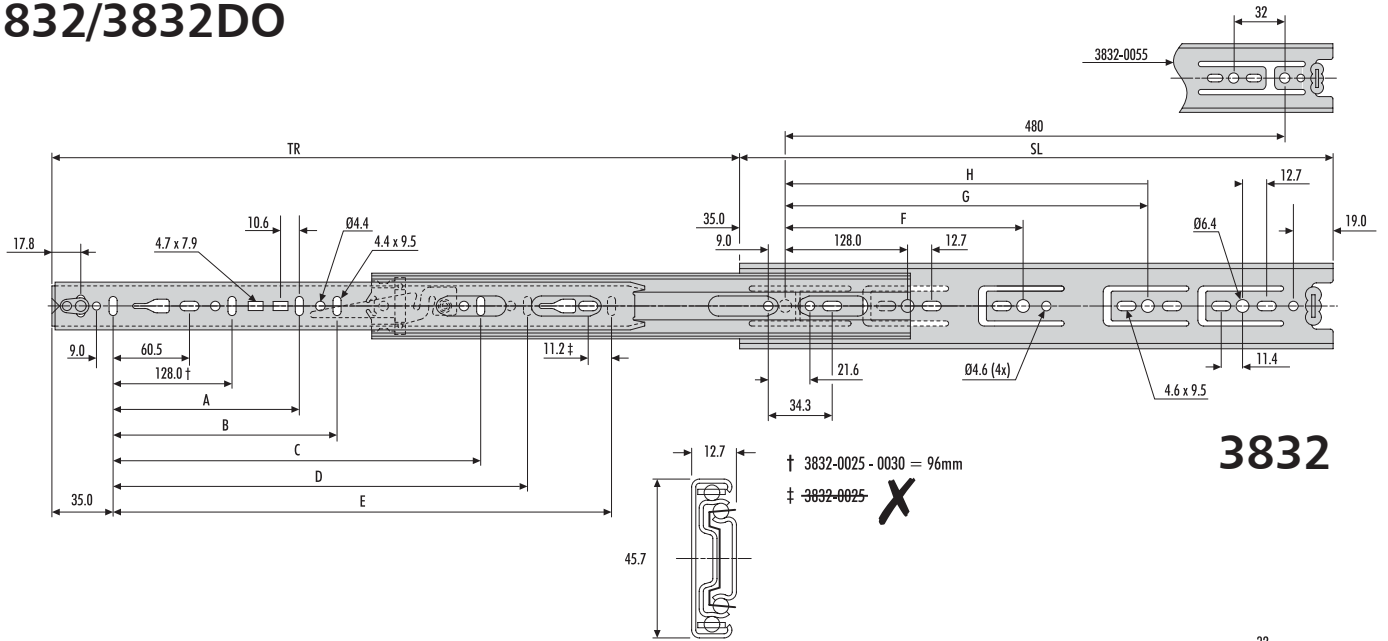

3832

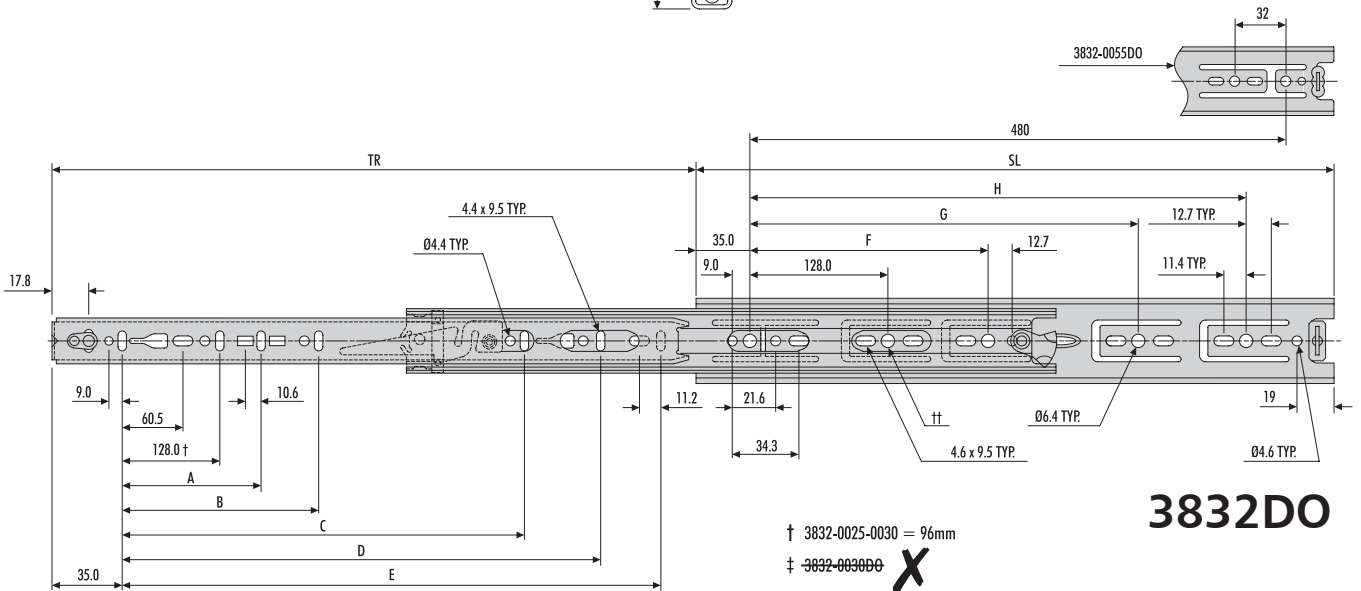

3832DO

3832/ 3832DO	mm									
	SL	TR	A	B	C	D	E	F	G	H
DZ3832-0025	250.0	243	-	-	-	-	192	-	-	-
DZ3832-0030	300.0	305	-	-	-	-	242	224	-	-
DZ3832-0030DO	300.0	305	-	-	-	-	242	224	-	-
DZ3832-0035	350.0	355	-	-	-	-	292	224	-	-
DZ3832-0035DO	350.0	356	-	-	-	-	292	224	-	-
DZ3832-0040	400.0	406	-	-	-	-	342	224	320	-
DZ3832-0040DO	400.0	406	-	-	-	-	342	224	320	-
DZ3832-0045	450.0	457	-	-	320	-	392	224	352	-
DZ3832-0045DO	450.0	457	-	-	320	-	392	-	352	-
DZ3832-0050	500.0	508	-	-	320	-	442	224	416	-
DZ3832-0050DO	500.0	508	-	-	320	-	442	-	416	-
DZ3832-0055	550.0	559	-	-	320	416	492	224	352	448
DZ3832-0055DO	550.0	559	-	-	320	416	492	-	352	-
DZ3832-0060	600.0	610	224	-	416	-	542	224	352	480
DZ3832-0060DO	600.0	610	224	-	416	-	542	224	352	480
DZ3832-0065	650.0	660	224	-	416	544	592	224	352	544
DZ3832-0065DO	650.0	660	224	-	416	544	592	224	352	544
DZ3832-0070	700.0	711	224	288	416	544	642	224	352	544
DZ3832-0070DO	700.0	711	224	288	416	554	642	224	-	544

3832HDSC/3832SC

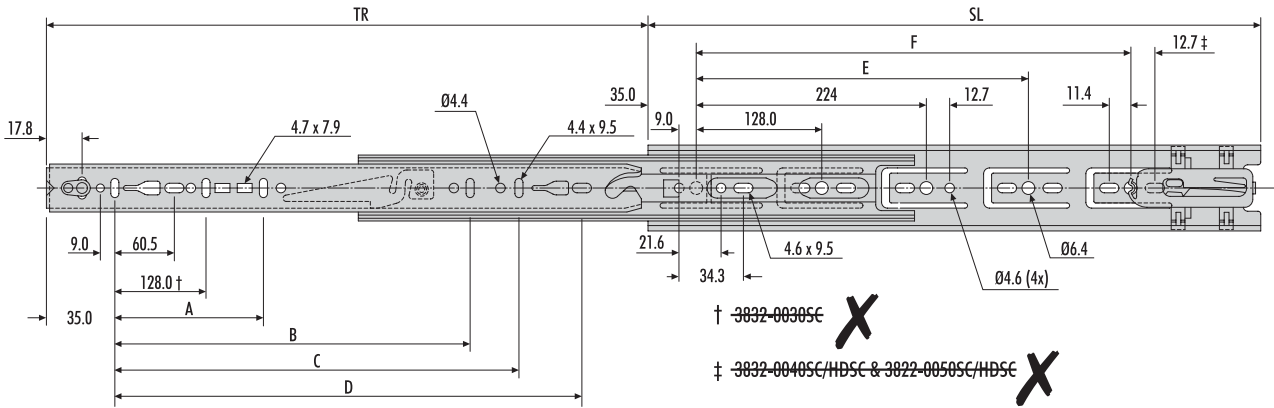
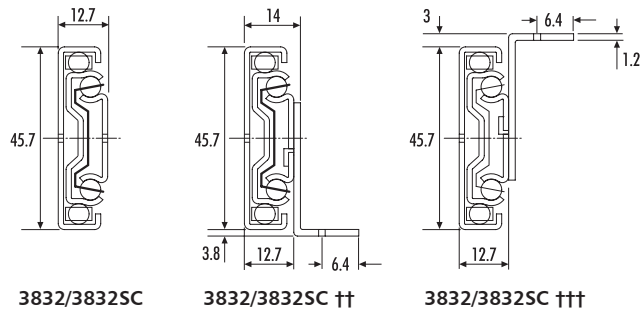

3832SC/ 3832HDSC	mm							
	SL	TR	A	B	C	D	E	F
3832-0030SC	300	286	-	-	-	231	-	-
DZ3832-0030HDSC	300	286	-	-	-	231	-	-
*3832-0035SC	350	356	-	-	-	281	-	-
DZ3832-0035HDSC	350	356	-	-	-	281	-	-
*3832-0040SC	400	406	-	-	-	331	288	-
DZ3832-0040HDSC	400	406	-	-	-	331	288	-
*3832-0045SC	450	457	-	320	-	381	320	-
DZ3832-0045HDSC	450	457	-	320	-	381	320	-
*3832-0050SC	500	508	-	-	-	431	384	-
DZ3832-0050HDSC	500	508	-	-	-	431	384	-
*3832-0055SC	550	559	-	416	-	481	416	-
DZ3832-0055HDSC	550	559	-	416	-	481	416	-
*3832-0060SC	600	610	224	416	-	531	352	480
DZ3832-0060HDSC	600	610	224	416	-	531	352	480
*3832-0065SC	650	660	224	416	544	581	352	512
DZ3832-0065HDSC	650	660	224	416	544	581	352	512

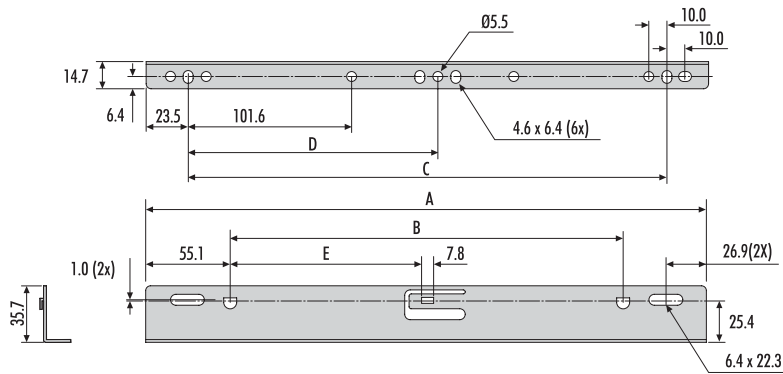

2132/3832		mm				
		A	B	C	D	E
DZ63335	3832-0035 -	346.7	236.5	300.0	150.0	114.4
63340	3832-0040 2132-40	396.7	286.6	350.0	175.0	139.4
DZ63345	3832-0045 2132-45/60/65/70	446.8	336.6	400.0	200.0	164.4
DZ63350	3832-0050 2132-50	496.8	386.6	450.0	225.0	189.4
DZ63355	3832-0055/60/65/70 2132-55	546.8	436.6	500.0	250.0	214.4

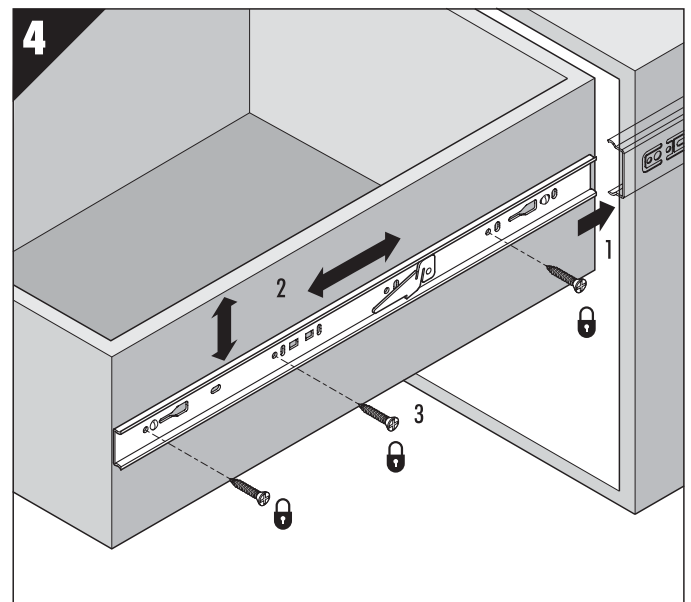
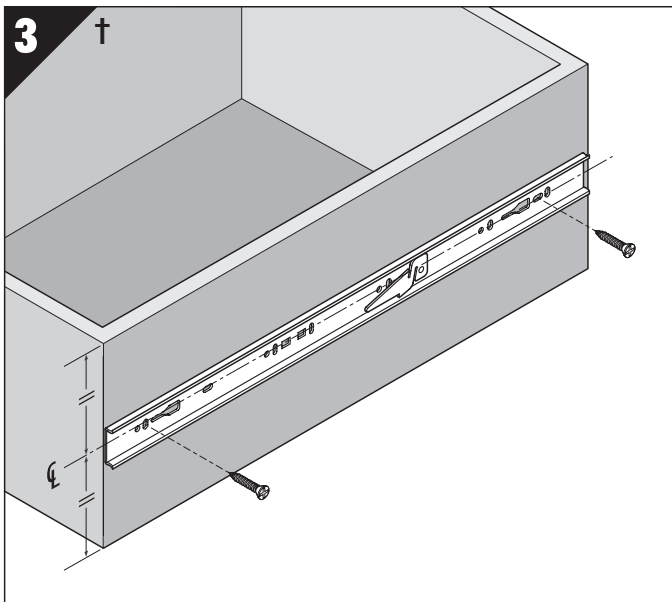
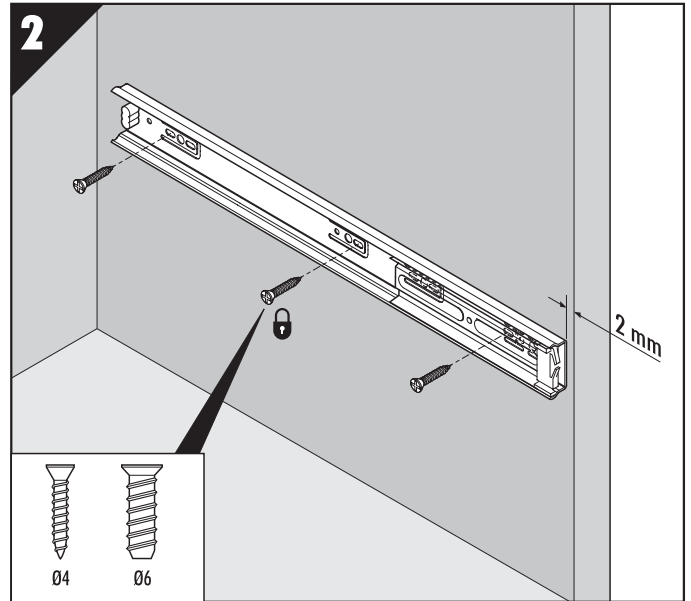
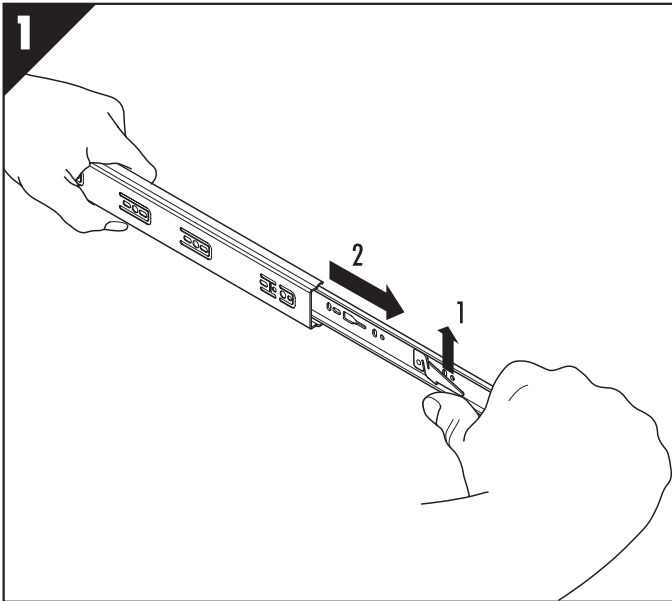

- GB** * Key slots and central cut-out only on lengths which accommodate the bottom bracket.
 † See overleaf for Bottom Mount and Platform Mount.
 †† Bottom Mount.
 ††† Platform Mount.

- D** * Langlöcher nur in Längen, die den Aufsteckwinkel aufnehmen.
 † Aufliegende und Tablar montage siehe umseitig.
 †† Aufliegende Montage.
 ††† Tablar montage.

- F** * Découpes spécifiques latérales et carré central uniquement sur les longueurs qui reçoivent l'équerre de montage.
 † Pour les montages sous tiroir et sous tablette, voir au verso.
 †† Montage sous tiroir.
 ††† Montage sous tablette.

- I** * Asole e apertura centrale solo su lunghezze che usano staffa di montaggio sul fondo.
 † Per il montaggio sul fondo e a piattaforma vedere a tergo.
 †† Montaggio sul fondo.
 ††† Montaggio a piattaforma.

- E** * Chaveteros y recorte central sólo en longitudes que acomodan la abrazadera inferior.
 † Véase al dorso para montaje inferior y de plataforma.
 †† Montaje inferior.
 ††† Montaje de plataforma.

- S** * Nyckelhålsöppning och centralt hål endast på de längder som är för monteringskena.
 † Se nästa sida för bottenmontering och plattformmontering.
 †† Bottenmontering.
 ††† Plattformmontering.

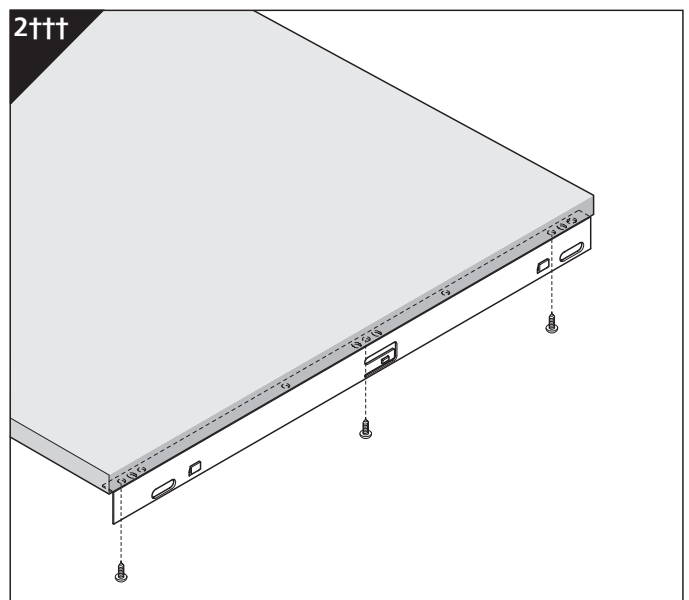
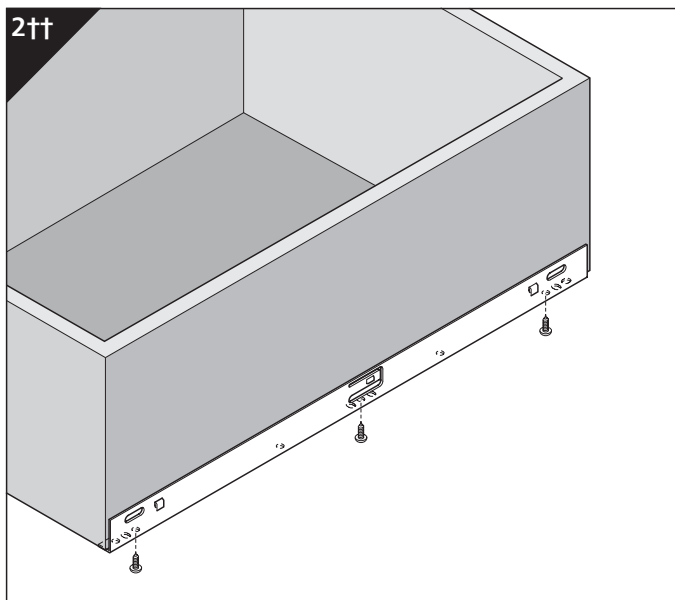
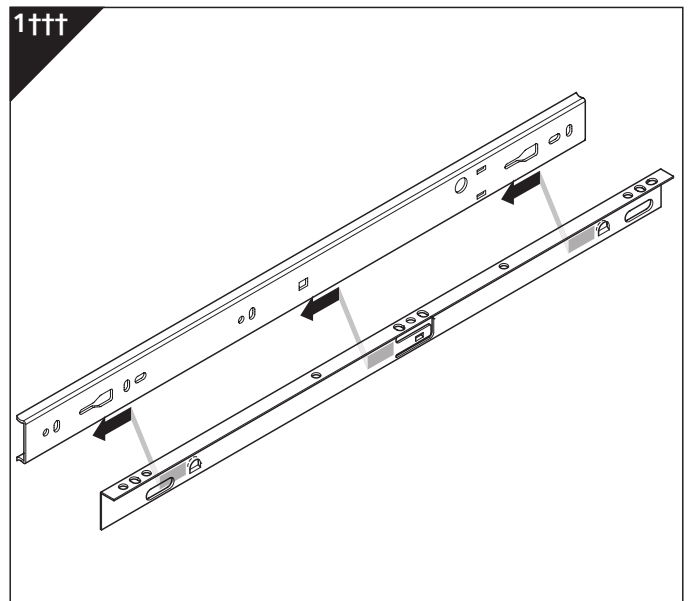
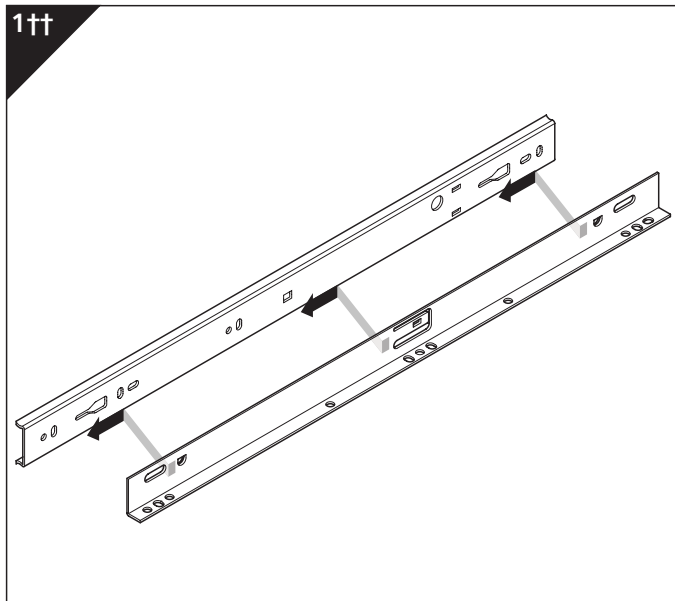

Accuride International Ltd.

Liliput Road, Brackmills Industrial Estate, Northampton
NN4 7AS, United Kingdom.

Tel: +44 (0) 1604 761111 Fax: +44 (0) 1604 767190

E-mail: saleseurope@accuride.com

www.accuride-europe.com

GB If you require further assistance, please contact your distribution agent or supplier.
Accuride reserve the right to alter specifications without notice.

D Bei Fragen wenden Sie sich bitte an Ihren Vertriebspartner.
Technische Änderungen vorbehalten.

F Pour de plus amples renseignements, veuillez contacter votre distributeur.
Accuride se réserve le droit de modifier les spécifications sans préavis.

Accuride International GmbH

Werner-von-Siemens-Str. 16-18,
D-65582 Diez/Lahn, Germany

Tel: + 49 (0) 6432 608-0 Fax: + 49 (0) 6432 608-320

www.accuride.de

I Qualora necessitate di ulteriore assistenza, contattate il fornitore o il vostro agente.
Accuride si riserva il diritto di apportare modifiche senza ulteriore comunicazione.

E Si necesita más ayuda, póngase en contacto con su agente de distribución o proveedor.
Accuride se reserva el derecho de alterar las especificaciones sin aviso previo.

S Om det krävs mer hjälp, var vänlig kontakta distributionsombud eller leverantör.
Accuride reserverar sig för ev konstruktionsändringar.