

1

Spring Adjustment - The spring tension needs to be calibrated to the weight of the LCD Screen. If the screen rises of its own accord the tension is too high. Using the T-Bar Hafele key turn the screw anti-clockwise. If the screen droops the tension is too low. Using the T-Bar Hafele Key turn the screw clockwise.

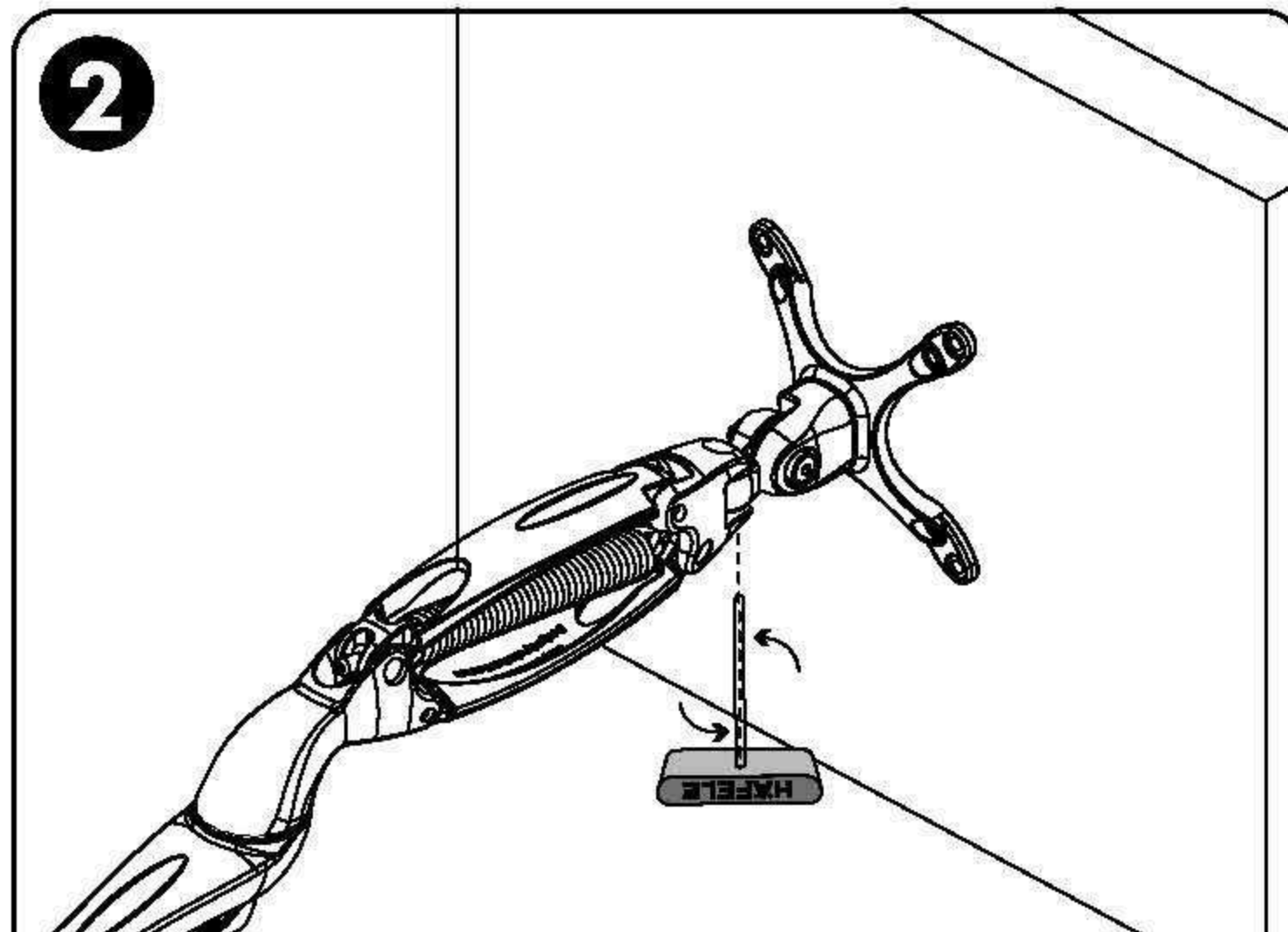

2

Swivel Adjustment - If the screen swings from left to right too freely the tension of the Swivel Joint can be tightened by applying the T-Bar Hafele Key to the domed nut on the underside and turning it anti-clockwise until sufficient tension is applied.

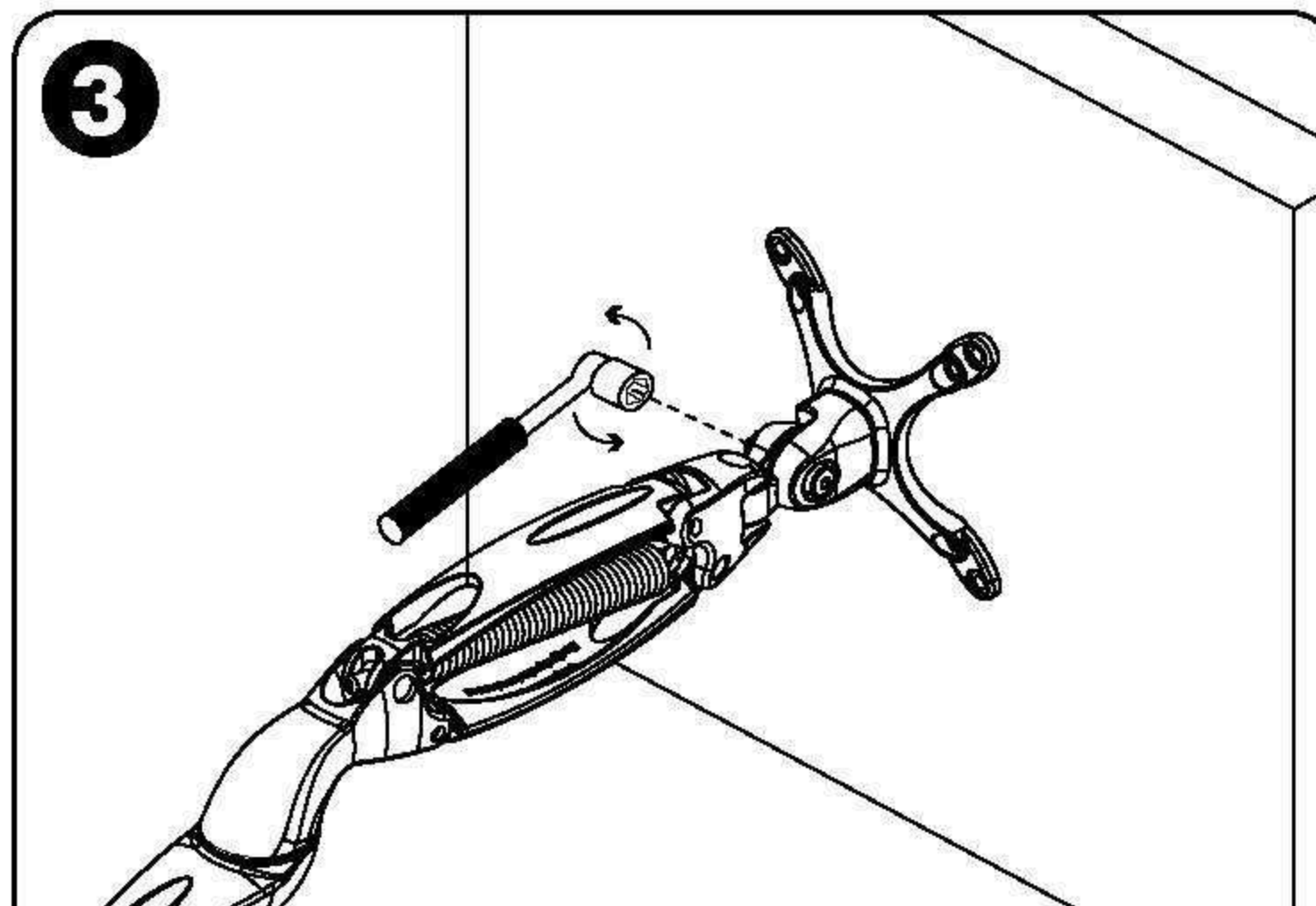

3

Tilt - The Tilt Joint has been pre-tightened with sufficient torque to ensure you can adjust your screen to an appropriate angle. If your screen droops, additional torque can be applied by using an 8mm socket wrench applied to the locking nut on the left hand side of the arm.