

# ASSEMBLY INSTRUCTIONS

## Canopy System Beta / Item No. 9402

Rev .00  
Nov.2002

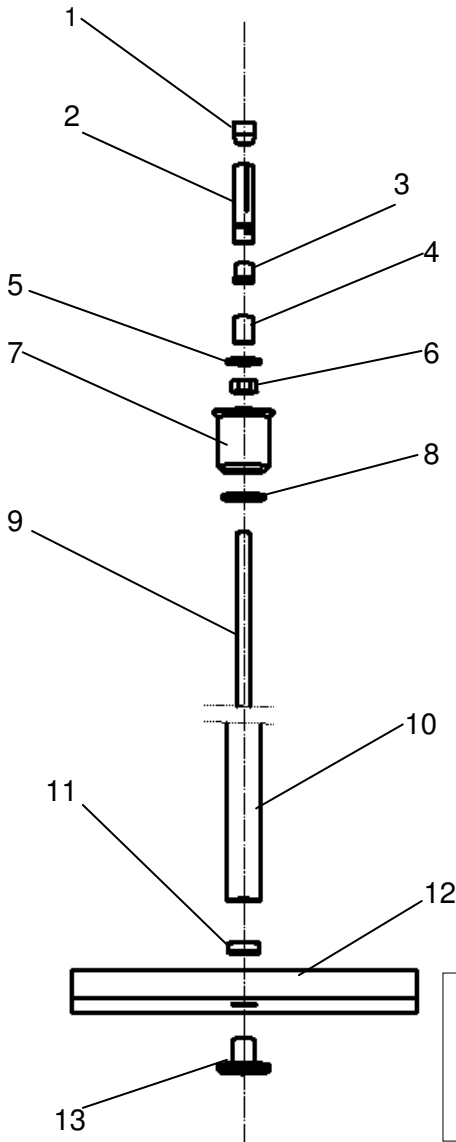
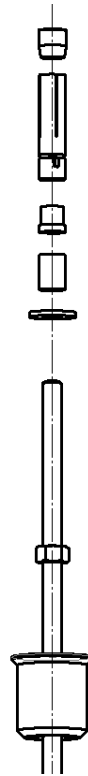
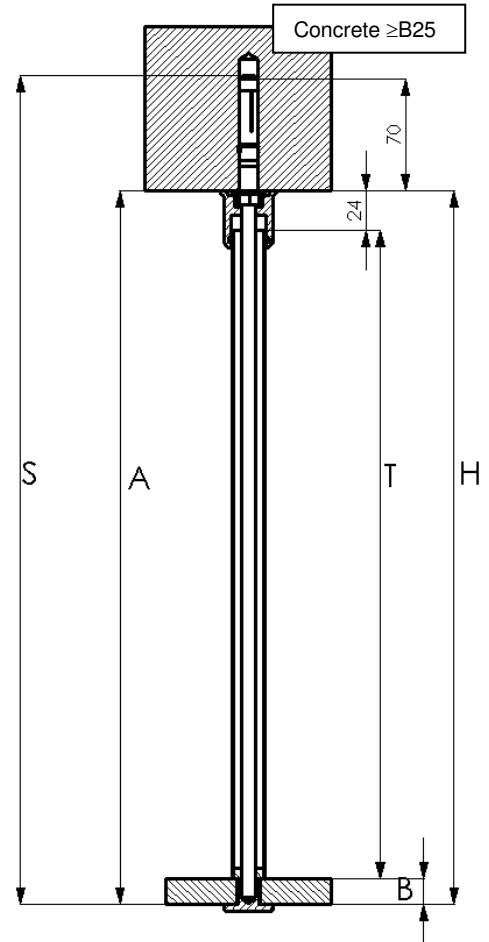

Illustration 1



$$\begin{aligned}
 A &= H \\
 A &= S - 70\text{mm} \\
 T &= H - 24\text{mm} - B \\
 H &= T + 24\text{mm} + B \\
 S &= A + 70\text{mm}
 \end{aligned}$$

Bearing surface thickness  $B=10$  mm min.(for glass)  
Load capacity for suspended element 50 kg  
Mount only below concrete ceilings( $\geq$  B25).  
The suspended bearing surfaces must correspond to the estimated load.



- |         |  |
|---------|--|
| Item 1  | 1x High-capacity anchor part 1                             |
| Item 2  | 2x High-capacity anchor part 2                             |
| Item 3  | 1x High-capacity anchor part 3                             |
| Item 4  | 1x High-capacity anchor part 4                             |
| Item 5  | 1x Washer $\varnothing$ 8.4mm                              |
| Item 6  | 1x Hexagon nut M8  |
| Item 7  | 1x Bush  |
| Item 8  | 1x O-ring $\varnothing$ 20 x 2.5mm                         |
| Item 9  | 1x Threaded rod M8   |
| Item 10 | 1x Tube $\varnothing$ 20 mm                                |
| Item 11 | 1x Eccentric ring  |
| Item 12 | 1x Suspended base is not included in the scope of delivery |
| Pos. 13 | 1x Carrying bolt   |

- Determine the position for the ceiling mounting drilling hole
- Drill a 12 mm diameter hole 80 mm in depth.
- Insert the O-ring, item 8, into the bush, item 7.
- Screw the bush, item 7 and hexagon nut M8, item 6 approx. 90 mm onto the threaded rod M8 x 1000 mm.
- Equip the parts as shown in illustration 1 and screw on item 1. For this purpose the thread of the threaded rod, item 9, must project 2-3 mm above the high-capacity anchor part 1, item 1.
- Insert the threaded rod with attached parts (illustration 1) by 80 mm into the 12 mm diameter bore and screw in firmly using the hexagon nut, item 6 (25Nm).
- Screw or push the tube, item 10, eccentric ring, item 11 and suspended base with 14 mm diameter bore, item 12 onto the threaded rod and screw on using the carrying bolt, item 12.

**We reserve the right to make alterations expedient to technical progress.**