

COLOMA SYSTEM

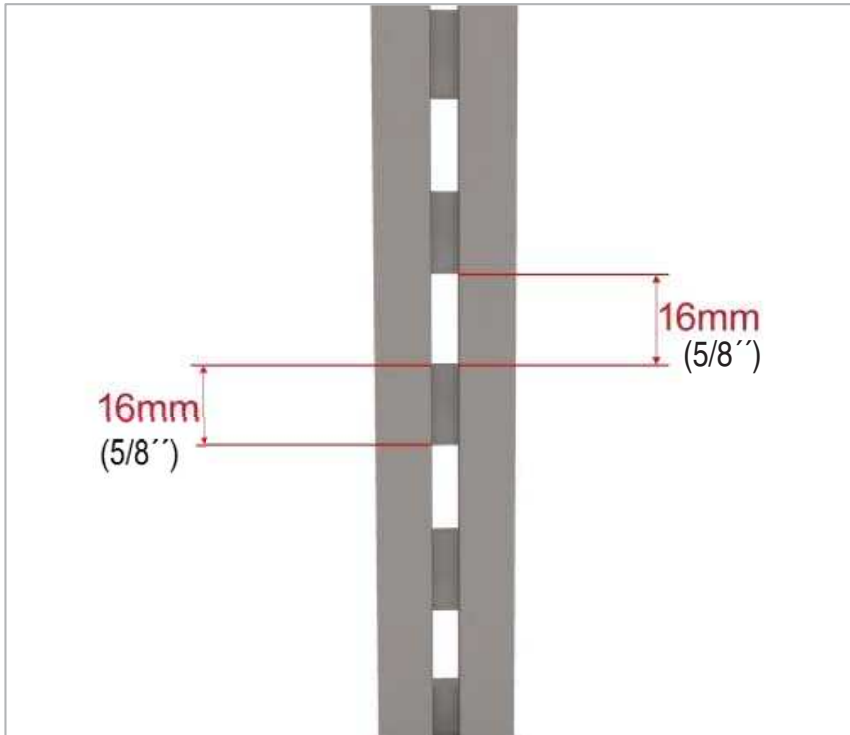

Slotted profile preparation and installation



All slotted profiles must be oriented in the same direction during installation and should only be cut from the top. This ensures that all slots will be at the same height so drawers and shelves are evenly mounted.

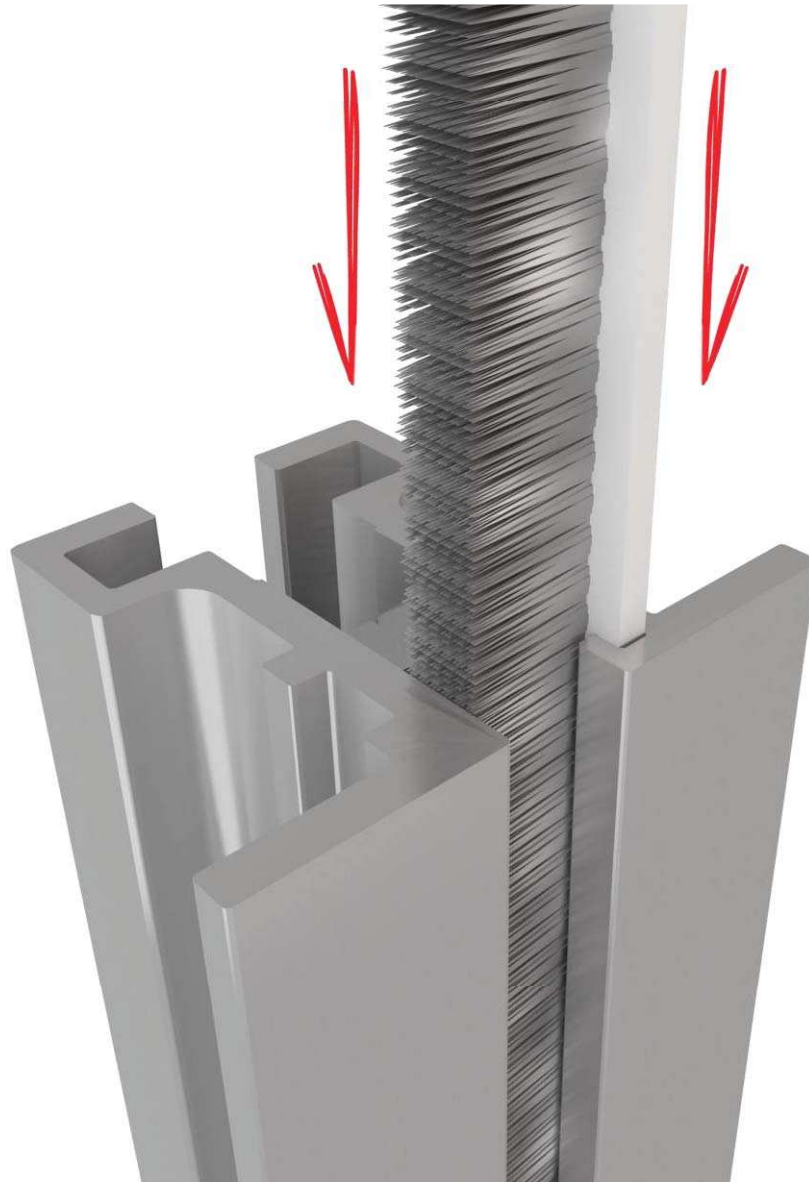
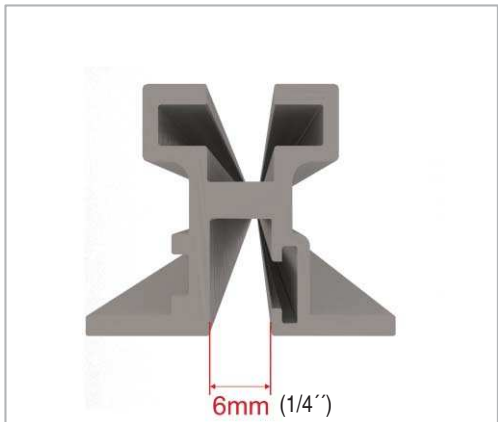
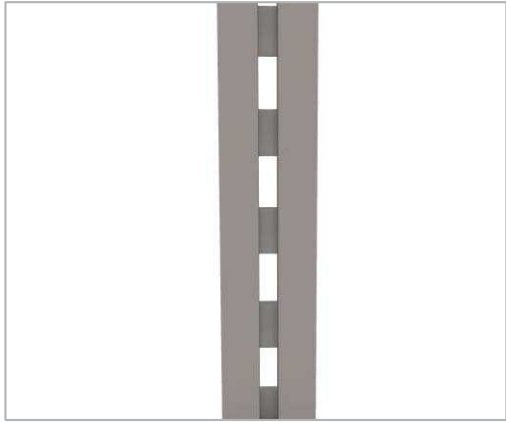

Insert the cover brush into the slotted profile. This will help conceal the slots.

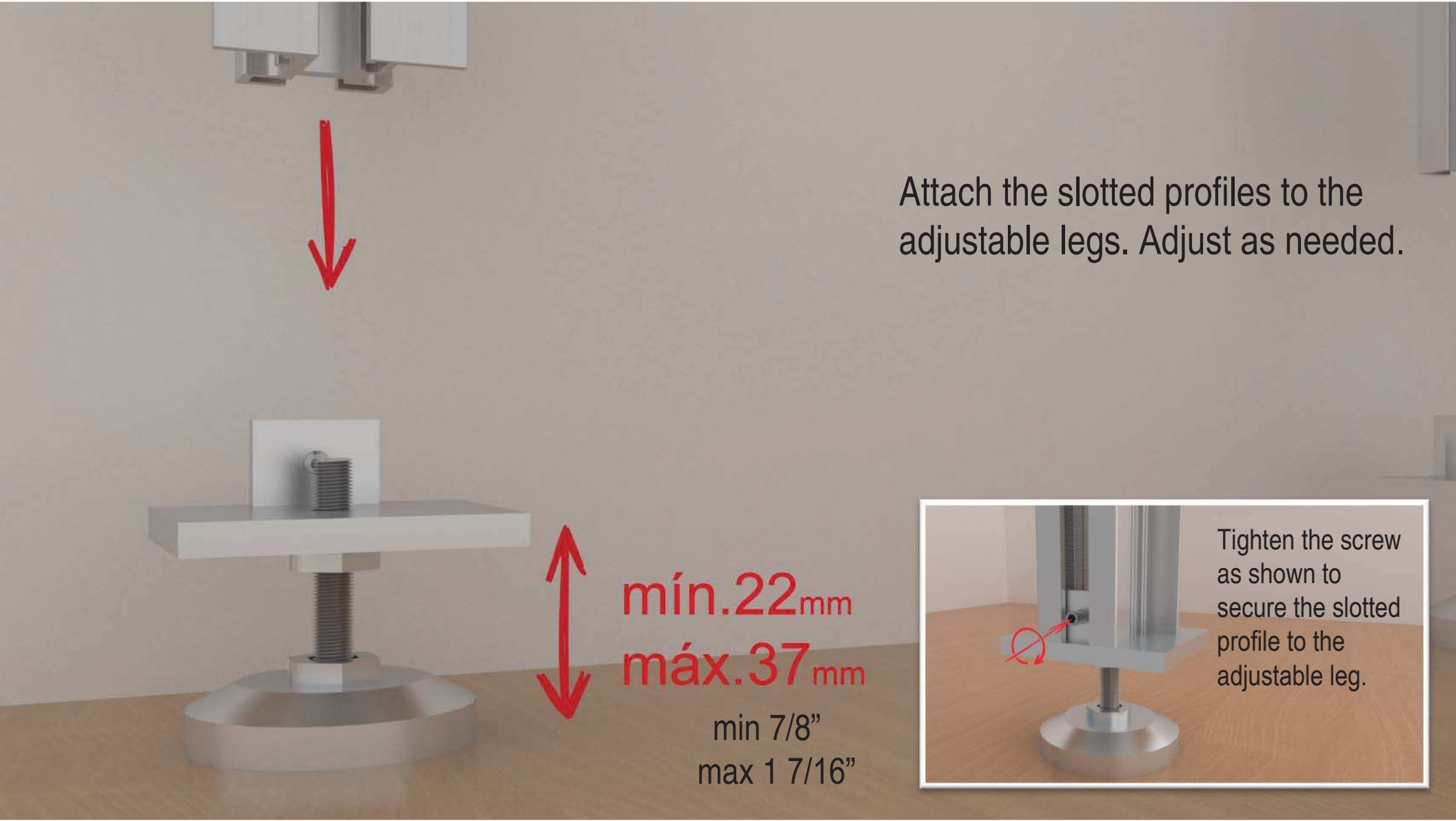

Attach the slotted profiles to the adjustable legs. Adjust as needed.



mín.22mm
máx.37mm
min 7/8"
max 1 7/16"



Tighten the screw as shown to secure the slotted profile to the adjustable leg.



Insert wall fasteners into slotted profile before attaching it to the wall.

Single-sided wall fasteners are shown in this illustration. These are specifically designed for ends and corners.

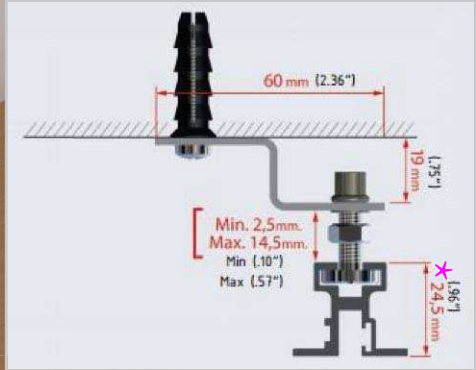
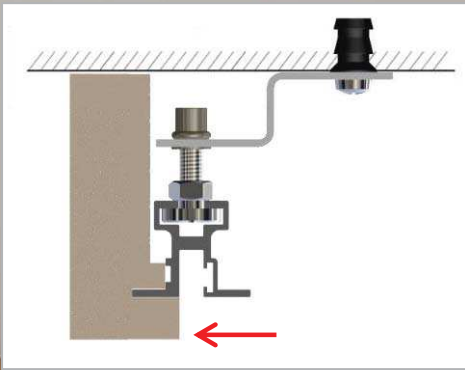

* This dimension has been changed. It is 30 mm (1 3/16").

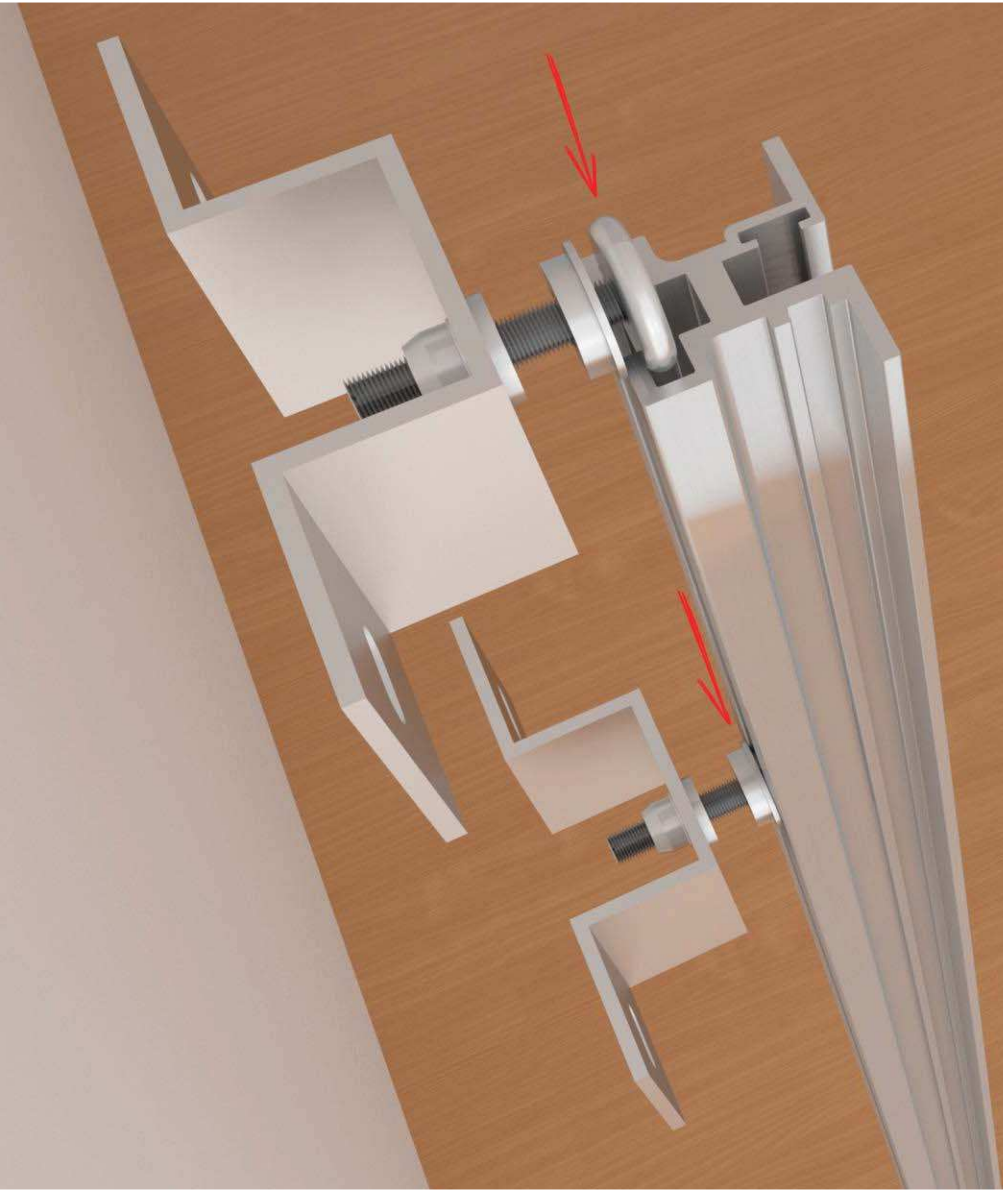

Double-sided wall fasteners are shown in this illustration. These are designed for installation into slotted profiles which are mounted in between panels.

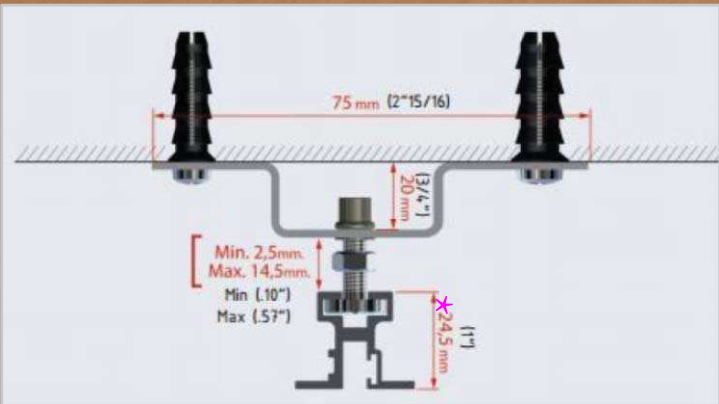

* This dimension has been changed. It is 30 mm (1 3/16").

Wall fasteners must be mounted no more than 610 mm (24") apart.

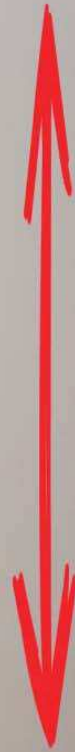

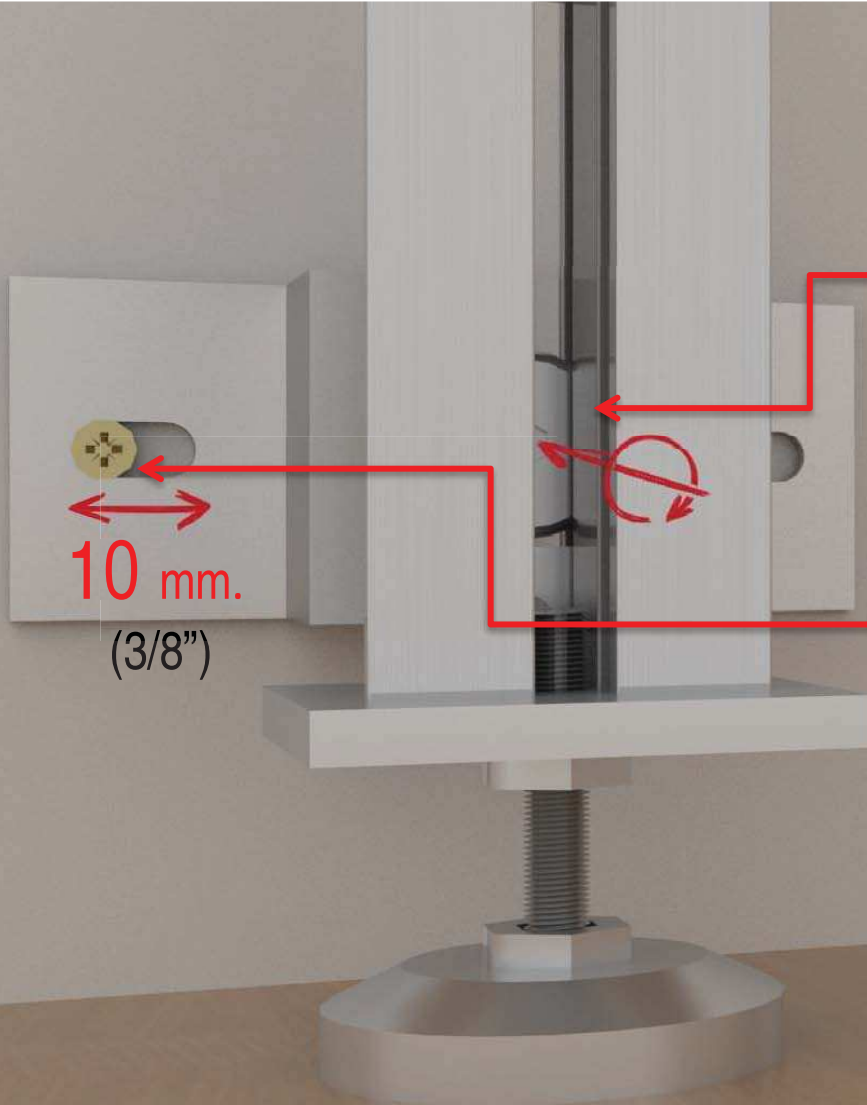

Adjust depth via the center screw on the wall fastener.

Slotted holes on the wall fastener allow for side adjustment.

When all adjustments are complete, tighten the locknut.



Back panel preparation and installation

The Coloma system is designed to use 19 mm (3/4'') back panels.

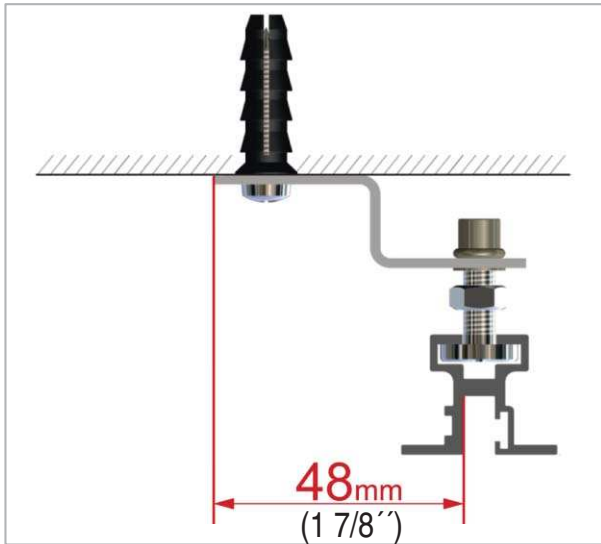

"X" is the width of the back panel. "X" must be equal to the space between the slot openings in the two installed, slotted profiles.

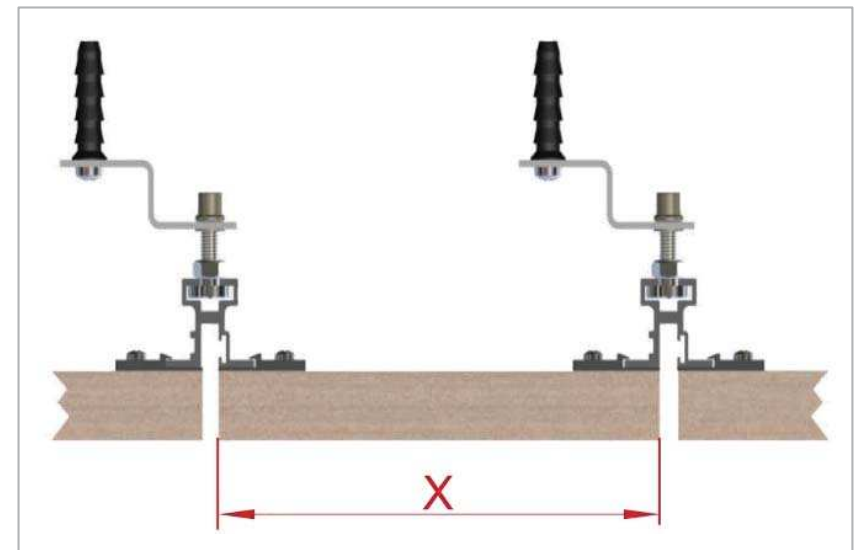
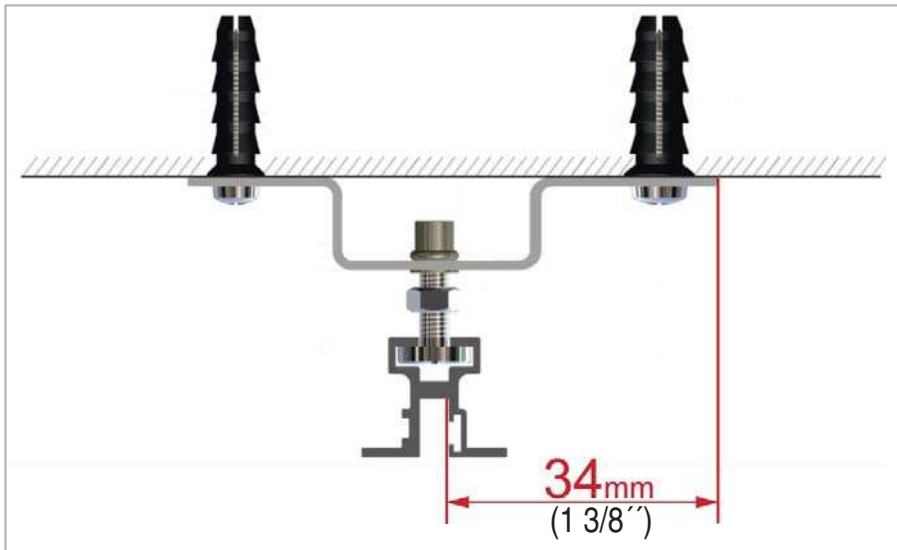

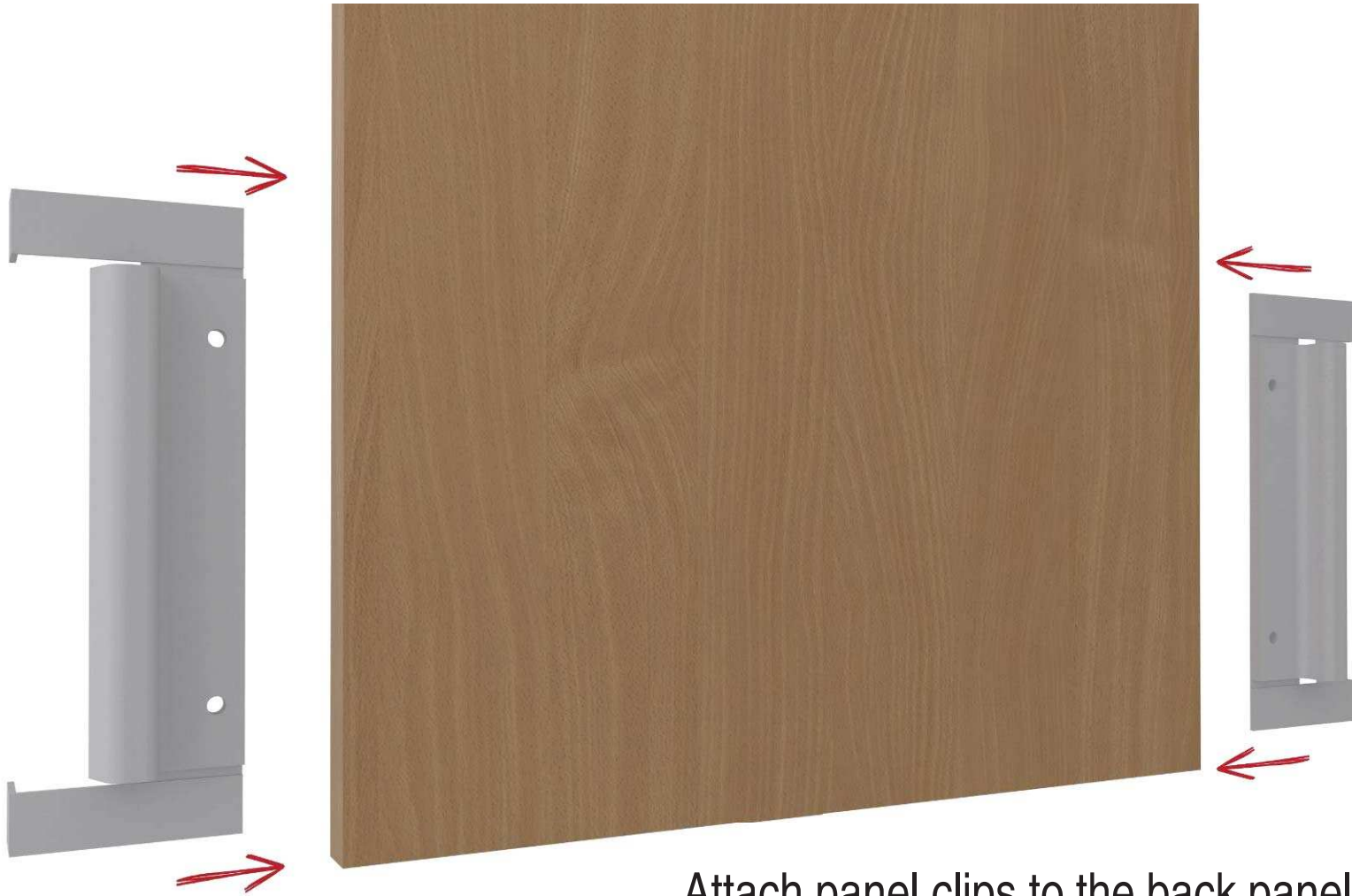

Attach panel clips to the back panel. Clips are designed with breakaway positioning tabs for quick and easy installation and alignment.

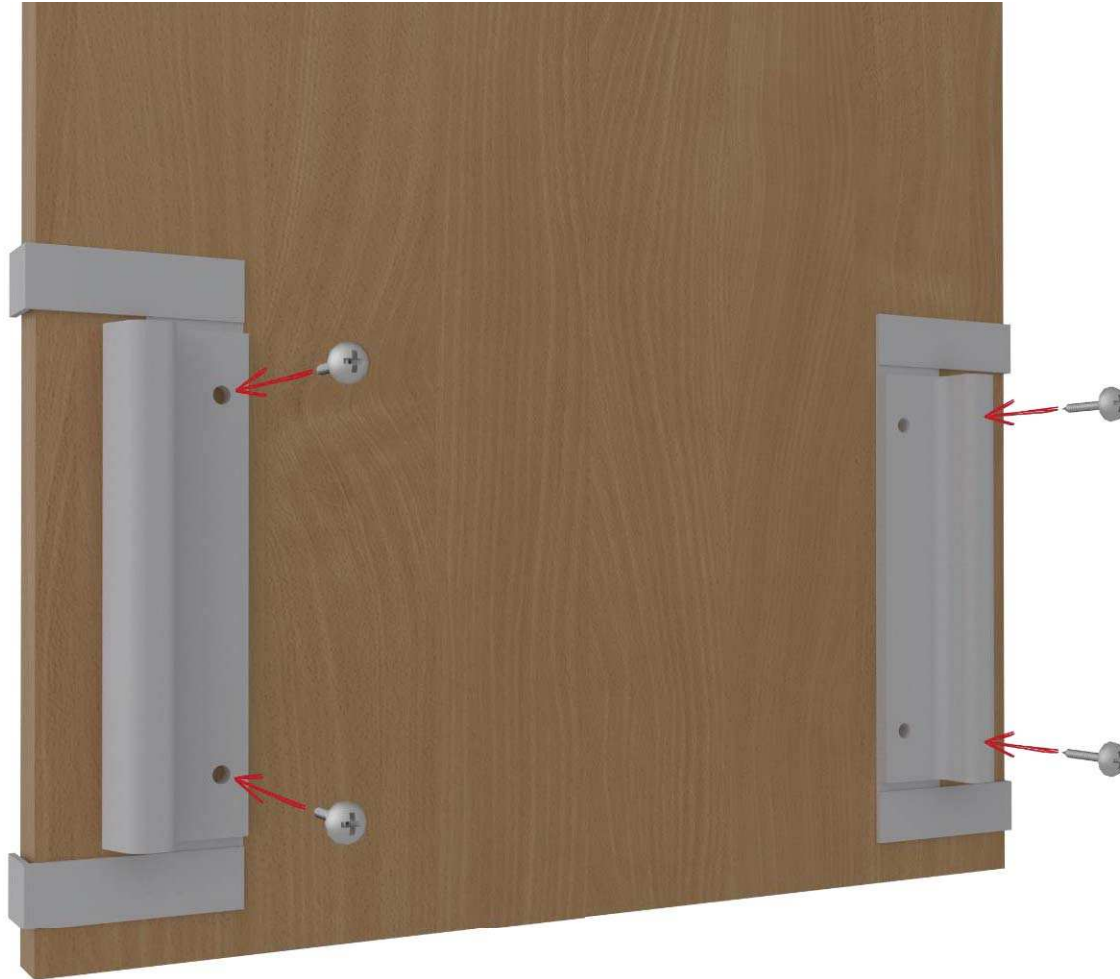

Attach panel clips. Eight are required per panel.



Remove breakaway positioning tabs.



Back panels are ready to be installed.

Install back panel by press fitting in between slotted profiles.





Back panels are installed and secure.





Adjustable legs were previously leveled so additional leveling is not required

Shelf bracket preparation and installation

Screw the brackets to the shelf. Note that all Coloma brackets are handed.

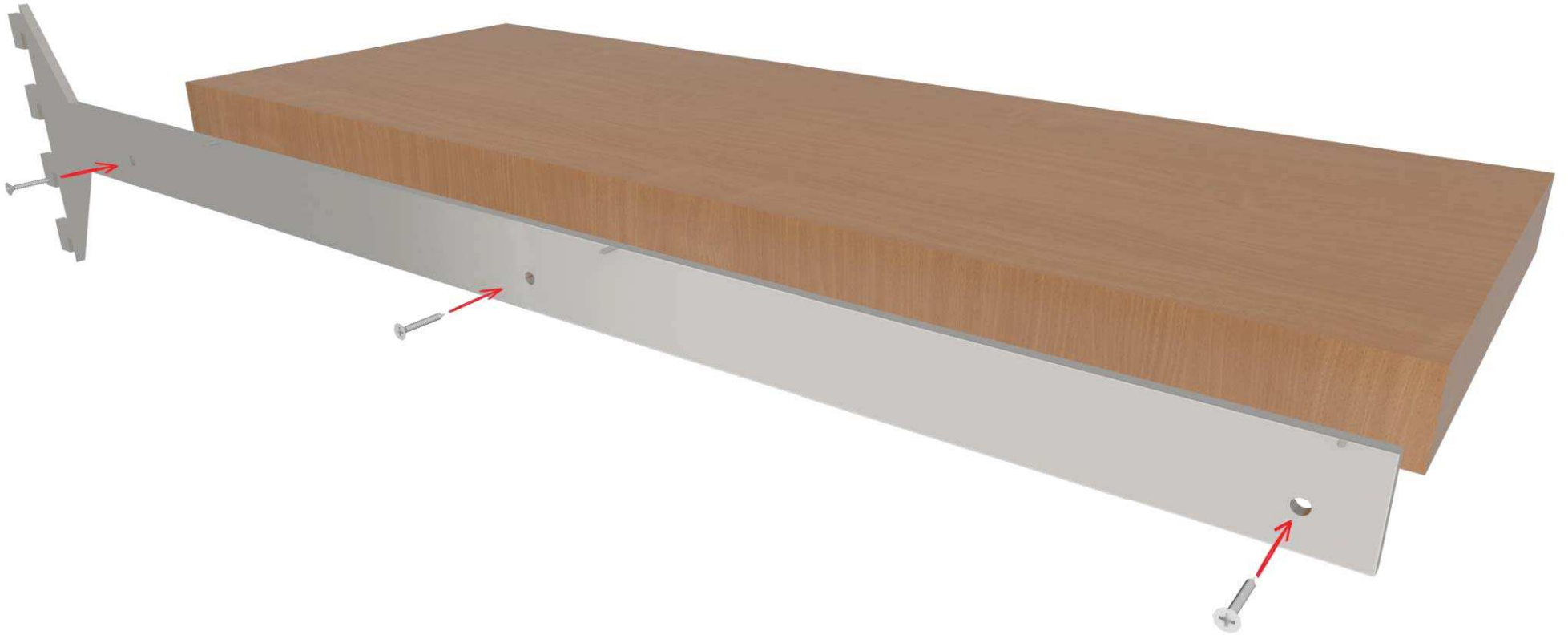

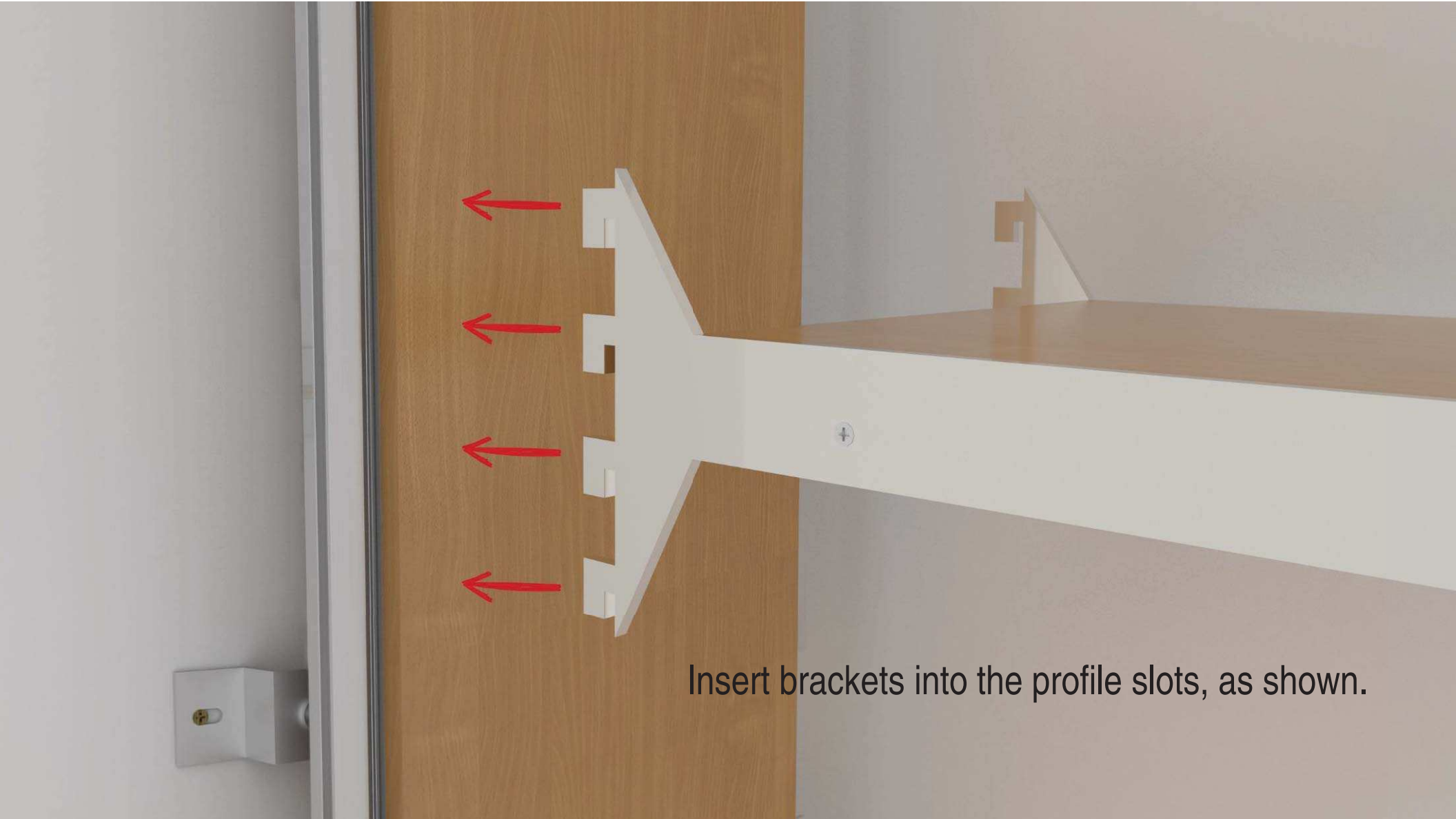

Insert brackets into the profile slots, as shown.

Push the shelf down to lock it.

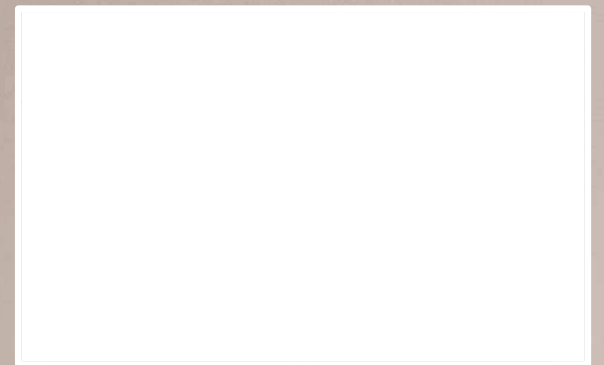

Bracket Options

For shelf thicknesses of 1 1/8" (28.6mm) and 1 1/2" (38mm).
The width of each shelf is always the same as the back panel.
Brackets allow shelves and drawers to be independently adjusted.

Bottom Shelf Bracket

A toe kick should be installed under the bottom shelf for additional support. Recommended height: 2 3/4" (70mm) to 3 11/32" (85mm) from the bottom.

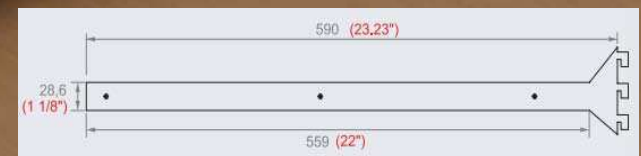

22" option shown

Shelf Bracket

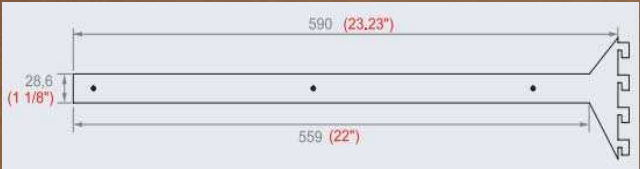

22" option shown

Glass Shelf Bracket

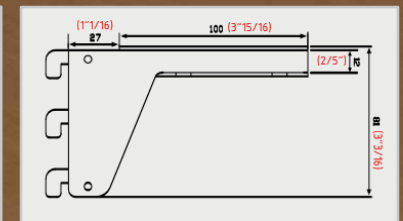
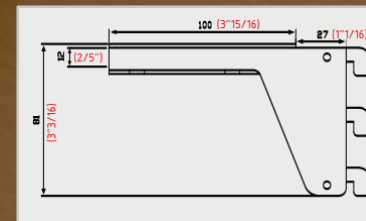

Drawer Bracket



22" option shown

Concealed Drawer Bracket

It is recommended to use a second set of concealed brackets to provide additional stability to the drawer.



Corner Options

Application I

Single or double sided wall fasteners can be used. Single sided are shown on this application.

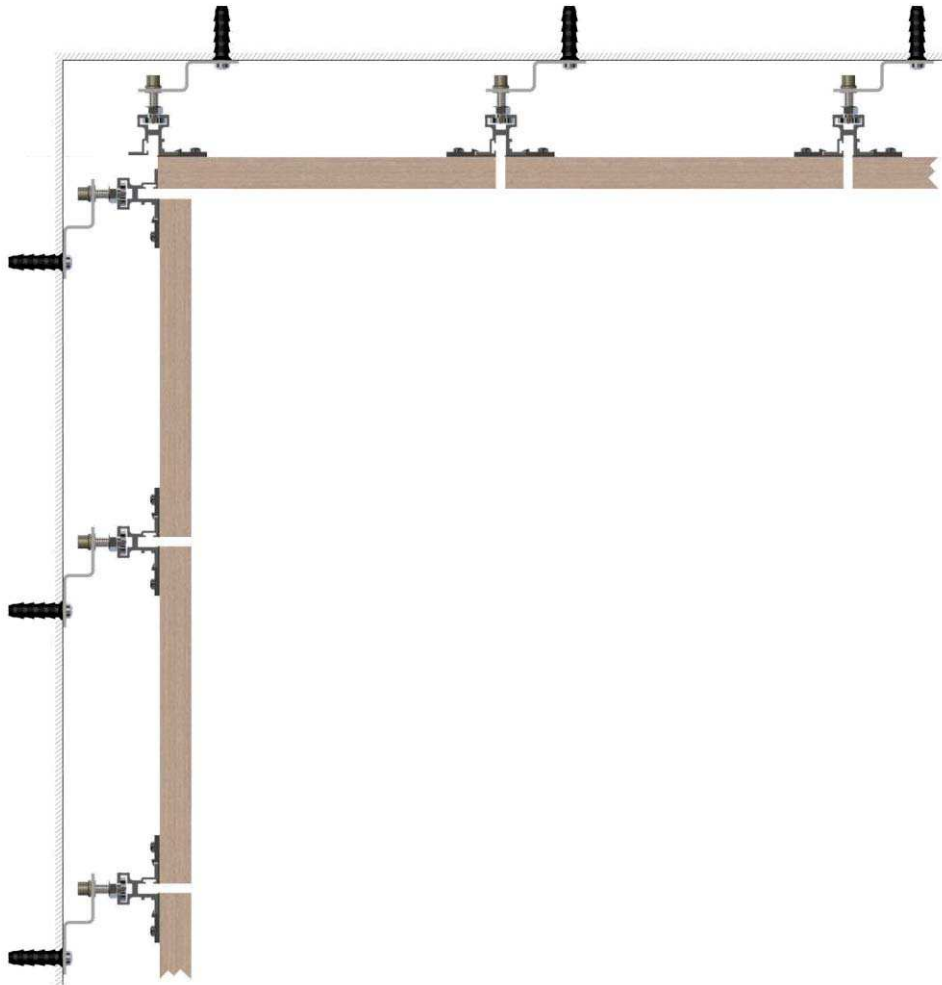

Application II

Single or double sided wall fasteners can be used. Single sided are shown on this application.

