

Item No.: 942.72.000

SLIDO POCKET DOOR FRAMING KIT

1) Preparation of the rough opening:

- Make sure rough opening is level and square. Frame the rough opening based on the following parameters:
- Rough opening width "A":
 - Calculation for a single pocket sliding door:
 $A = 2 \times \text{door width} + 13/16" (21 \text{ mm})$.
 - Calculation for a bi-parting pocket sliding door:
 $A = 4 \times \text{door width} + 1/16" (2 \text{ mm})$.
- Rough opening height 'B':
 - Using Slido Classic 40/P - 120/P fittings:
 $B = \text{door height} + 5 \frac{3}{8}" (137 \text{ mm})$.

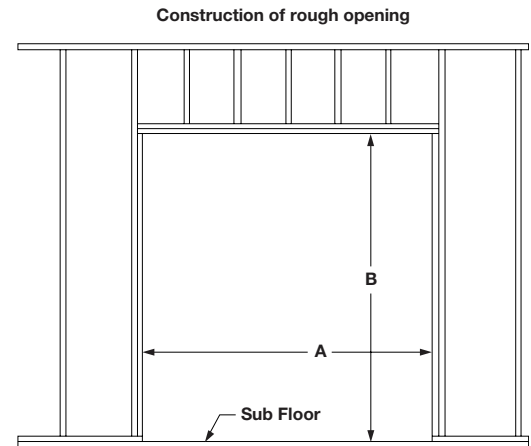

2) Preparation of the header assembly:

- Header assembly is pre-manufactured for 40" wide doors.
- Other standard door sizes are marked on the header assembly in the following increments (24", 28", 30", 32", and 36").
- Odd door widths have to be measured off.
- If necessary, cut header to the appropriate size on left and right.

Caution: Make sure that you cut the header assembly at the appropriate marks. The cutting points on the door side of the header assembly are different for a single pocket sliding door application in contrast to a bi-parting pocket sliding door application. On the pocket side of the header assembly the cutting points are identical.

- Pre-drill header in 4 - 5 locations: equal spaces across the header assembly. **See diagram 2.**

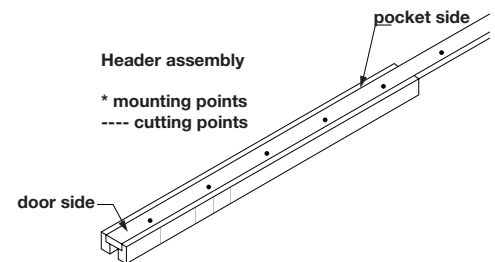

Item No.: 942.72.000

* = Locations of marks
 X = distance between sub floor
 & finished floor, determined in field

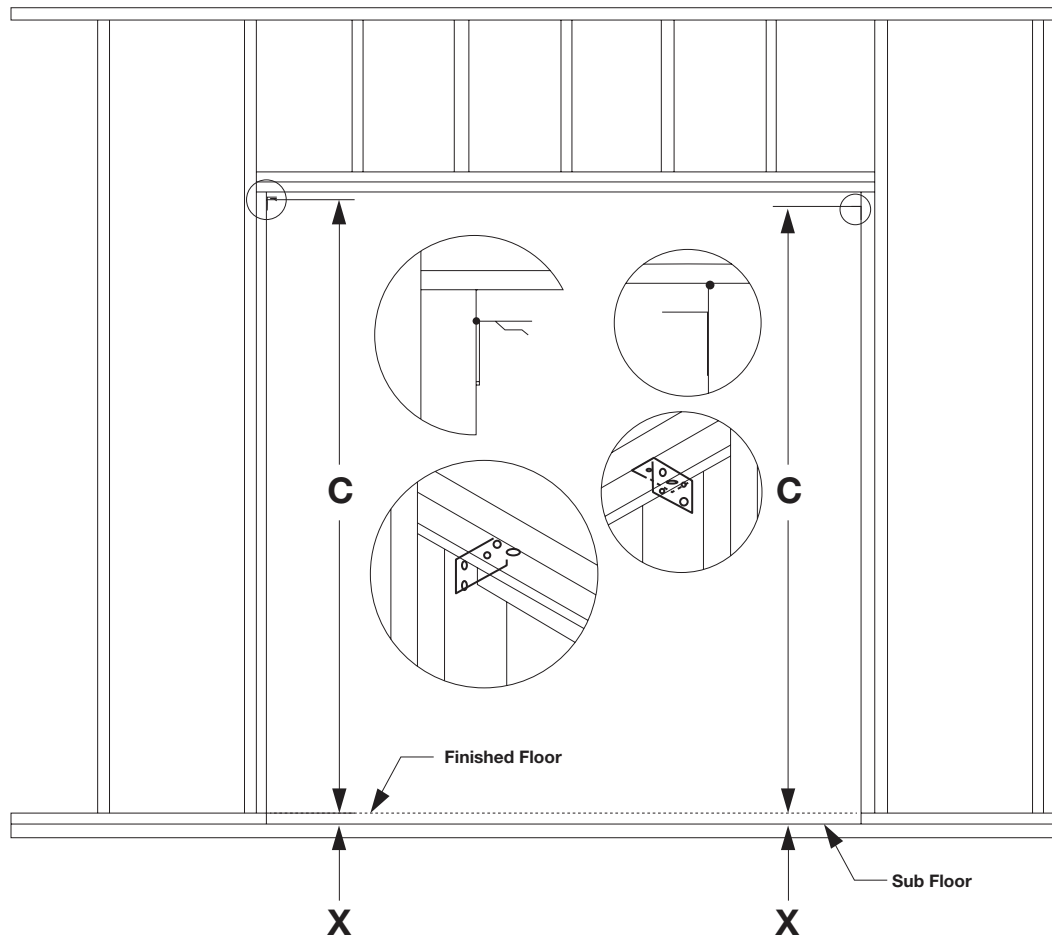

Diagram 3

3) Attaching header assembly

- Determine mounting locations of the open end bracket and the concealed end bracket. See dimension C on **diagram 3**. Dimension C equals 82 7/8" from the finished floor for an 80" tall door. In case the door is shorter the appropriate deduction has to be considered.
- Mark locations on the left and right stud of the opening with a square. **See diagram 3**.
- Attach mounting brackets with the provided screws. The top of the bracket should align with marked line on the stud. Also make sure that the open end bracket is mounted on the lock side of the pocket door while concealed end bracket is mounted on the pocket side of the pocket door. Brackets should be centered on the stud and should be level horizontally. (Use a plumb line, laser level, or straight edge)
- Insert the cut-to-size header assembly over the open end bracket on the locking side and place the other header assembly side on top of the concealed end bracket. Mediate the header assembly and attach with the provided screws. (Pre-drill before attaching since screws are pretty close to the end of the header assembly in order to avoid splitting of the wood)
- Fix header assembly in place by mounting it to the top structure of the rough opening. Make sure the header assembly is mounted square to the studs and shim accordingly to make it level across the opening. (Screws for mounting the header to the top structure are not provided)

Mounting Instructions

HÄFELE

Item No.: 942.72.000

4) Preparation of the Upper Track:

- Upper track is pre-manufactured for 40" wide doors.
- Other standard door sizes are marked on the upper track in the following increments (24", 28", 30", 32", and 36")
- Odd lengths have to be measured off.
- If necessary, cut upper track to the appropriate size on left and right.

Caution: In case you are cutting the upper track only on one side the preset keyhole won't work and the screw that is pre-mounted on the header assembly has to be re-positioned!!

- Insert running gears, track stoppers, and/or soft closing devices into upper track according to **diagram 4**. Make sure that all parts are facing the correct direction.
- Mount upper track by inserting the track into the open end of the concealed header bracket on the pocket side as well as slipping the keyhole of the upper track over the pre-mounted pan head screw of the header assembly.
- Screw upper track to the header assembly only in the accessible area of the opening.

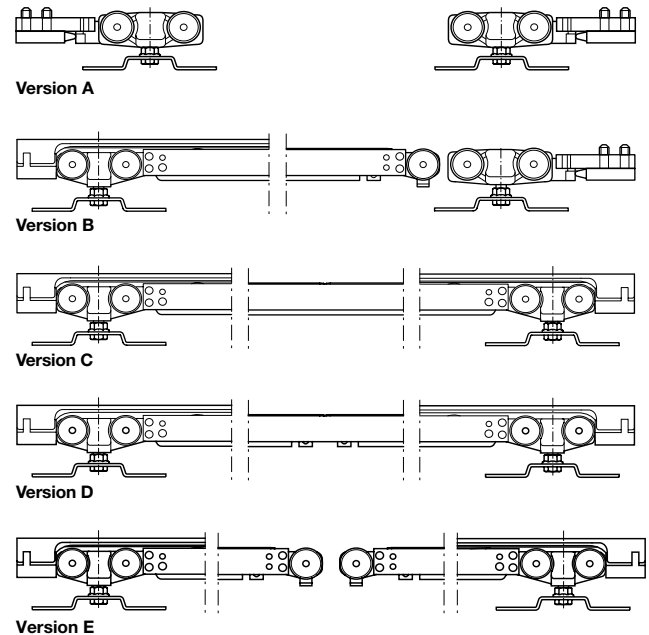

Diagram 4

Mounting Instructions

HÄFELE

Item No.: 942.72.000

5) Mounting of shoe plates and vertical steel studs:

- Snap a chalk line to assist in determining where to attach the shoe plates. **See diagram 5.**
- Measure the height of the vertical steel studs and cut to size, if necessary. Cutting should be done at the bottom of the profile so this way you don't lose the pre-drilled mounting holes for attaching the vertical studs to the header assembly.
- Attach shoe plates to sub-floor with provided screws as shown on **diagrams 5 and 6.**

Recommendation for correct placement of the shoe plates is to observe the following steps:

- Insert one of the front vertical studs into shoe plate.
- Mount this vertical stud to the header assembly.
- Use a level to plumb the first vertical stud and then attach the shoe plate to the floor with the provided fixing screws.
- Slip the second vertical stud in the fixed shoe plate and mount to the header assembly.

- Repeat these steps for the back vertical profile. Please make sure that you mediate the back vertical studs between the front vertical stud and the house structure.

Note: The front vertical studs have nailing strips which have to face towards the lock side of the pocket door.

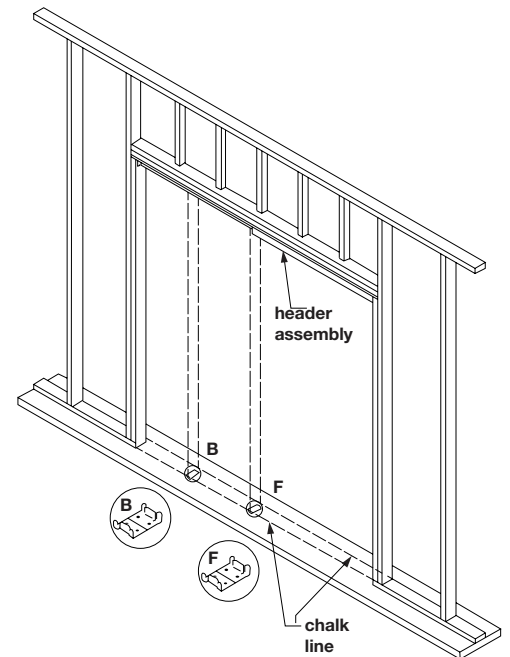

Diagram 5

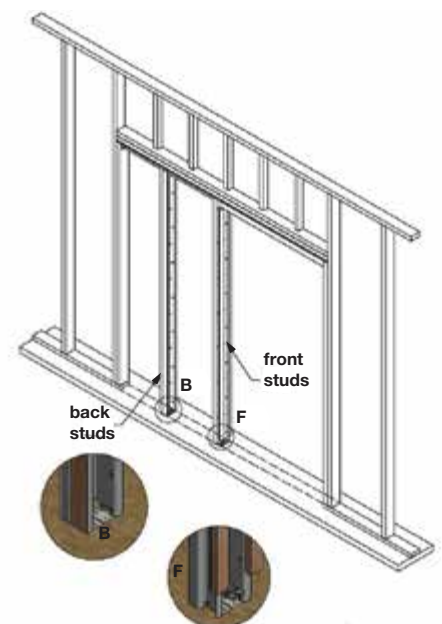

Diagram 6

Mounting Instructions

Item No.: 942.72.000

6) Preparation of floor guide:

- If not pre-fabricated, mill a groove in the bottom of the sliding door. **Diagram 7**
- Depending on the height of the finished floor, you may need to add a block of wood under the floor guide to accommodate appropriate spacing. Mount floor guide between the front vertical studs as shown on **diagram 8**.

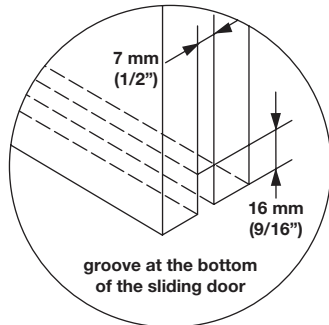

Diagram 7

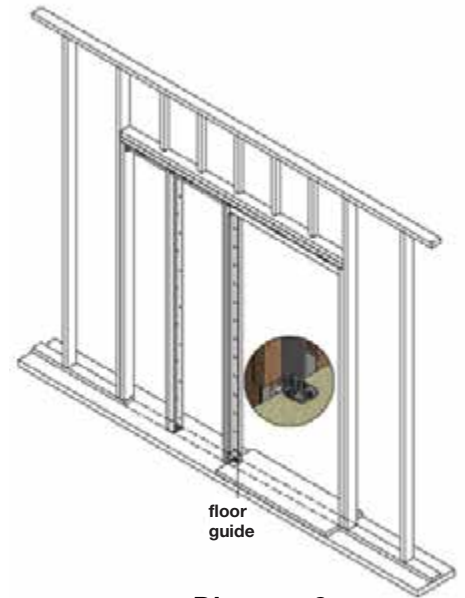

Diagram 8

7) Location of suspension plates on top of door

- **Note:** The dimensions listed to the right supersede the mounting instructions that come with the fitting sets.

8) Hang door

- Hang door onto suspension bolts that are attached to the running gear and adjust the door so that the door is plumb against jamb on the lock side of the pocket door opening. Recommended clearance between the finished floor and the bottom of the door is approximately 11 mm (7/16").
- Adjust the door stoppers or the release device of the soft closing mechanisms so the door stops in the correct and final position before dry walling.

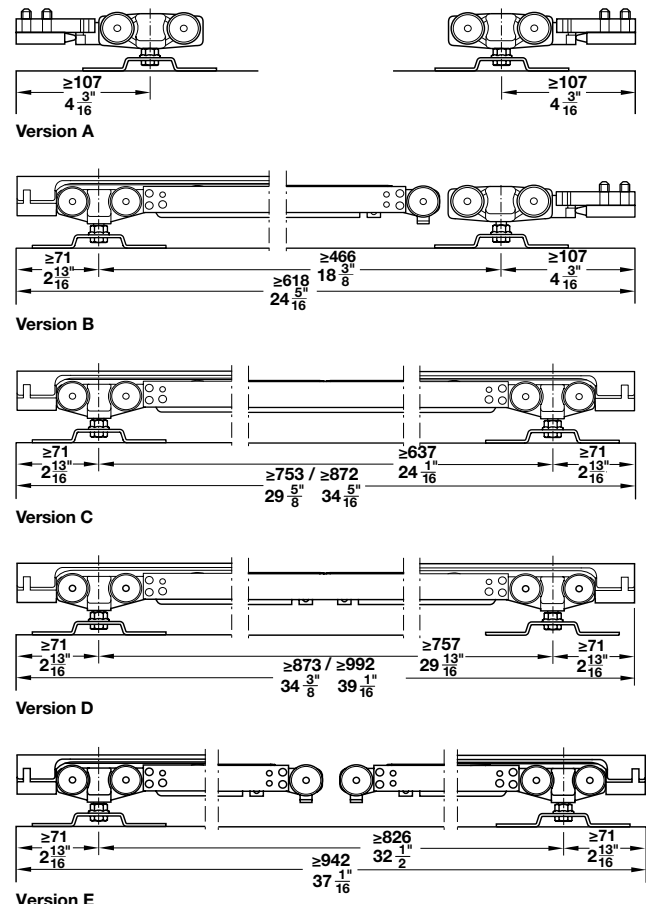

Diagram 9

Mounting Instructions



Item No.: 942.72.000

