

Specification Sheet

Part No.	Description	Last Updated
IB5/21	IB5/21 Indicator Bolt	04/10/99

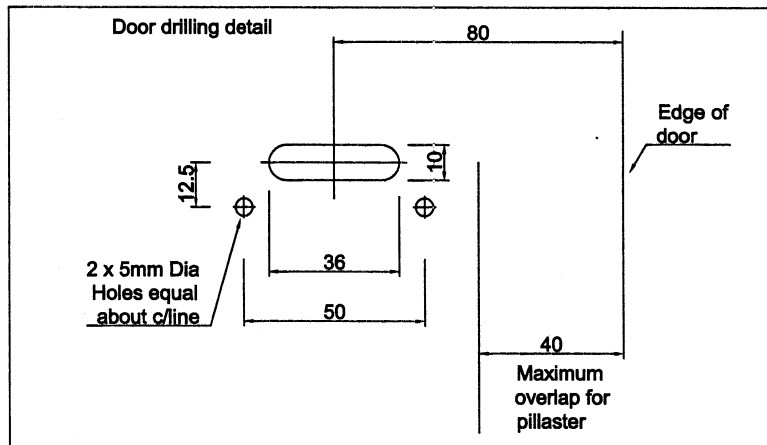
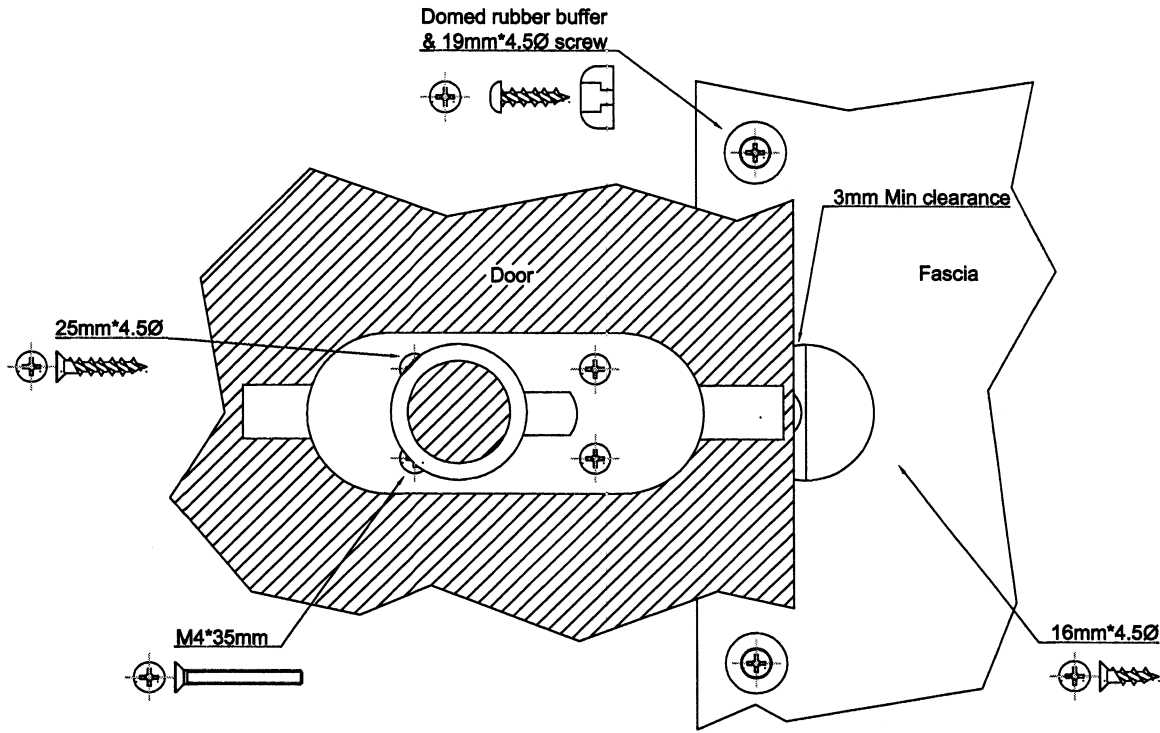

1. The door preparation for the indicator bolt requires two holes and a slot machining in the panel.
2. The first step is to decide the centre height of the indicator bolt (this is usually a matter of personal preference).
3. Mark the horizontal centreline of the bolt from the edge of the door to a distance approximately 100mm in.
4. Mark off and machine the door as shown on the drawing.
5. Fit the red/green signal into the round face plate, ensuring that the red sticker is closest to the bottom of the door and the two holes in the back of the face plate are at the bottom. Identify the two 35mm long machine screws and fit these into the bottom two holes on the shoot bolt assembly.
6. Offer the shoot bolt assembly to the door in the closed position, making sure the screws and slide pin fit into the pre machined holes, offer the face plate to the front of the door, align the screws and tighten firmly to clamp the indicator bolt to the door.

7. Using a small drill, pilot the top two holes in the shoot assembly to take the two 25mm long woodscrews. Fit the screws and tighten firmly.
8. Fit the two rubber buffers onto the back of the fascia approximately 150mm from the line of the top and bottom of the door.
9. Close the door and slide the bolt into the locked position.
10. Offer the keep into position and mark the back of the fascia.
11. Drill a 5mm hole to a depth of 8mm to accept the roll pin protruding from the back of the keep.
12. Swivel the keep until the unit is level and the shoot bolt engages easily, pilot the remaining hole and secure to the panel through the small plastic buffer with the remaining 16mm screw.

Specification Sheet

Part No.	Description	Last Updated
IB5-21out	IB5/21 Indicator Bolt outward opening situation	04/10/99

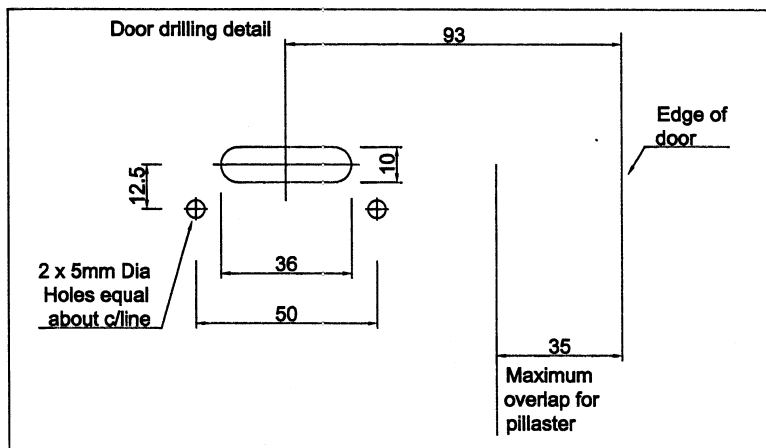
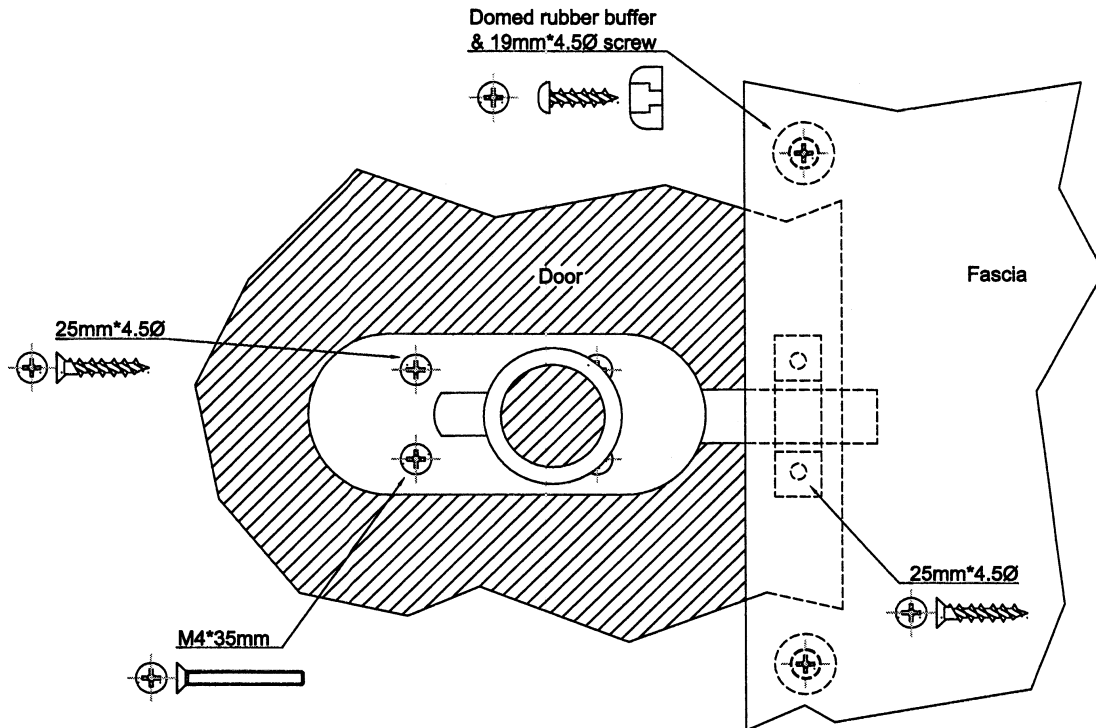

1. The door preparation for the indicator bolt requires two holes and a slot machining in the panel.
2. The first step is to decide the centre height of the indicator bolt (this is usually a matter of personal preference).
3. Mark the horizontal centreline of the bolt from the edge of the door to a distance approximately 100mm in.
4. Mark off and machine the door as shown on the drawing.
5. Fit the red/green signal into the round face plate, ensuring that the red sticker is closest to the bottom of the door and the two holes in the back of the face plate are at the bottom. Identify the two 35mm long machine screws and fit these into the bottom two holes on the shoot bolt assembly.
6. Offer the shoot bolt assembly to the door in the closed position, making sure the screws and slide pin fit into the pre machined holes, offer the face plate to the front of the door, align the screws and tighten firmly to clamp the indicator bolt to the door.

7. Using a small drill, pilot the top two holes in the shoot assembly to take the two 25mm long woodscrews. Fit the screws and tighten firmly.
8. Fit the two rubber buffers onto the front of the fascia approximately 150mm from the line of the top and bottom of the door.
9. Close the door and slide the bolt into the locked position.
10. Offer the keep into position and mark the front of the fascia.
11. Pilot drill two holes and secure the keep to the fascia using the 25mm screws provided.